

*UN CLASSICO NON SI CAMBIA,
SI PERFEZIONA.*

NEVER CHANGE A CLASSIC.
JUST REFINE IT.

LOS CLÁSICOS NO SE CAMBIAN.
SE PERFECCIONAN.

L1



L1

STAINLESS STEEL AISI304

made in Italy

SEMPLICITÀ, PROPORZIONE, ACCIAIO

Linea morbida dell'acqua che contrasta con la forma rigorosa dell'acciaio, che si contrappone all'elemento di comando cilindrico. La materia dell'acciaio e la trasmissione della lucentezza sono inversamente proporzionali.

Soft water line which contrasts with the strict form of steel, which is opposite to the element of cylindrical command. The material of steel and the transmission of the glossiness are inversely proportional.

Linea de agua suave que contrasta la forma estricta de acero, que es contrarrestar el elemento de mando cilíndrico. La materia prima de acero y la transmisión del brillo son inversamente proporcionales.



L1
Monoacqua lavabo appoggio H 145 mm
Single lever basin tap only cold water for top mounting H 145 mm
Einhebelmischer H 145 mm
Grifo monomando de sobremesa para lavabo H 145 mm
Mitigeur pour lavabo sur plan H 145 mm uniquement pour eau froide

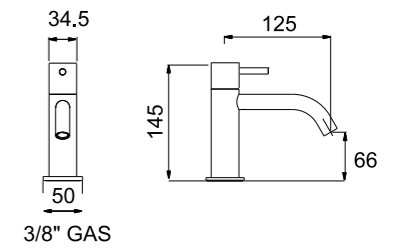

RA -rame/copper bronze GO -british gold GM -nero/gunmetal



L1
Miscelatore lavabo appoggio H 165 mm - con cartuccia tipo chiuso/bocca d.18 mm
Single lever basin mixer for top mounting H 165 mm
Einhebelmischer H 165 mm
Grifo monomando de sobremesa para lavabo H 165 mm
Mitigeur pour lavabo sur plan H 165 mm

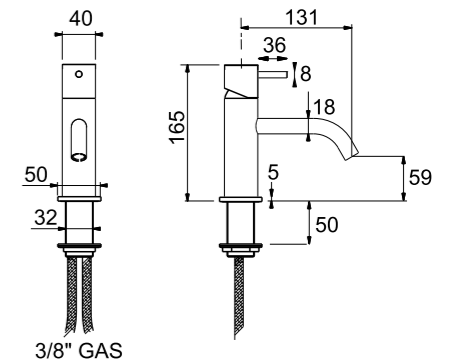

RA -rame/copper bronze GO -british gold GM -nero/gunmetal



L1
Miscelatore lavabo appoggio H 165 mm - con cartuccia tipo aperto/bocca d.18 mm
Single lever basin mixer for top mounting H 165 mm
Einhebelmischer H 165 mm
Grifo monomando de sobremesa para lavabo H 165 mm
Mitigeur pour lavabo sur plan H 165 mm

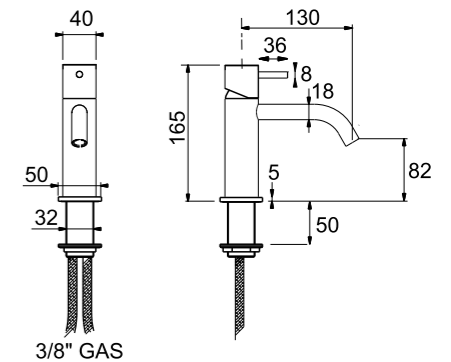

RA -rame/copper bronze GO -british gold GM -nero/gunmetal

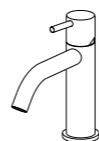

L1
Miscelatore lavabo appoggio H 165 mm - con cartuccia tipo aperto/bocca d.20 mm
Single lever basin mixer for top mounting H 165 mm
Einhebelmischer H 165 mm
Grifo monomando de sobremesa para lavabo H 165 mm
Mitigeur pour lavabo sur plan H 165 mm

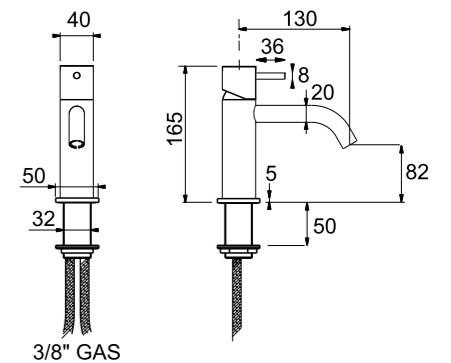

RA -rame/copper bronze GO -british gold GM -nero/gunmetal

IT	DE	EN	F
SA = Satinato	SA = Satiniert	SA = Satin	SA = Satinée
LU = Lucido	LU = Glänzend	LU = Polished	LU = Poli
PVD = Colori speciali	PVD = Sonderfarben	PVD = Special colour	PVD = Couleurs spéciales

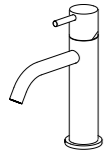

L1

Miscelatore lavabo appoggio H 220 mm

Single lever basin mixer for top mounting H 220 mm
Einhebelmischer H 220 mm
Grifo monomando de sobremesa para lavabo H 220 mm
Mitigeur pour lavabo sur plan H 220 mm

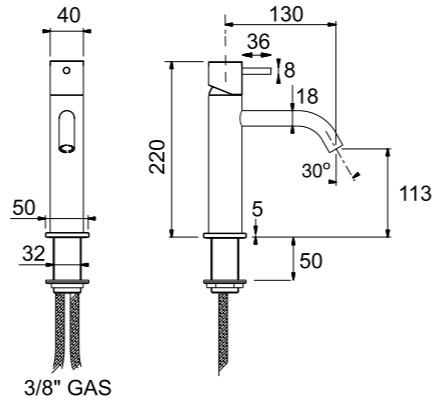

RA -rame/copper bronze GO -british gold GM -nero/gunmetal

3/8" GAS

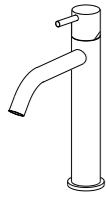

L1

Miscelatore lavabo appoggio H 260 mm

Single lever basin mixer for top mounting H 260 mm
Einhebelmischer H 260 mm
Grifo monomando de sobremesa para lavabo H 260 mm
Mitigeur pour lavabo sur plan H 260 mm

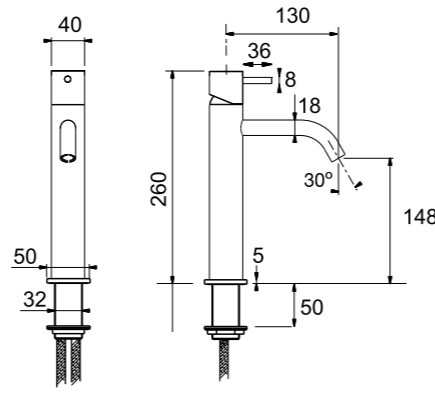

RA -rame/copper bronze GO -british gold GM -nero/gunmetal

3/8" GAS

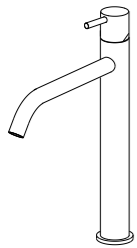

L1

Miscelatore lavabo appoggio H 350 mm

Single lever basin mixer for top mounting H 350 mm
Einhebelmischer H 350 mm
Grifo monomando de sobremesa para lavabo H 350 mm
Mitigeur pour lavabo sur plan H 350 mm

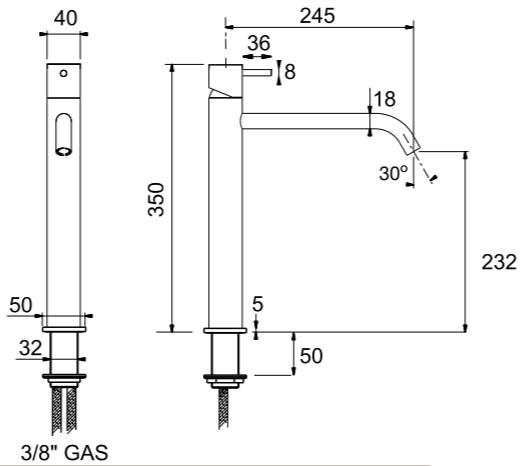

RA -rame/copper bronze GO -british gold GM -nero/gunmetal

3/8" GAS

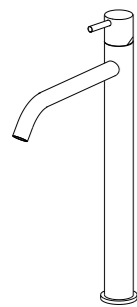

L1

Miscelatore lavabo appoggio H 450 mm

Single lever basin mixer for top mounting H 450 mm
Einhebelmischer H 450 mm
Grifo monomando de sobremesa para lavabo H 450 mm
Mitigeur pour lavabo sur plan H 450 mm

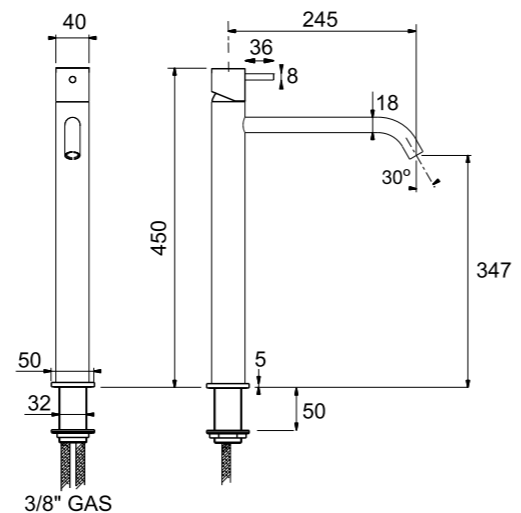

RA -rame/copper bronze GO -british gold GM -nero/gunmetal

3/8" GAS



L1

Miscelatore lavabo appoggio comando remoto

Deck mounted single lever basin mixer.
Einhebelmischer f. Standmontage - Durchfluss 20 l/Min.
Grifo monomando repisa.
Mitigeur lavabo sur plan avec support de commande à distance.

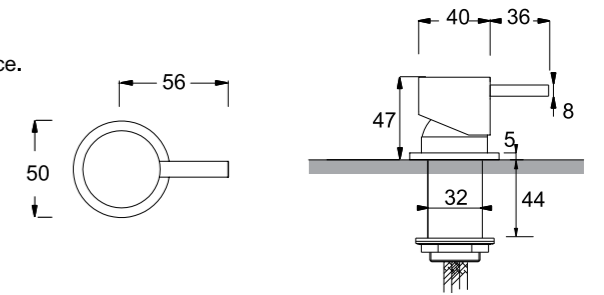

RA -rame/copper bronze GO -british gold GM -nero/gunmetal



L1

Miscelatore lavabo/vasca appoggio comando remoto alta portata

Deck mounted single lever basin mixer high flow
Einhebelmischer f. Standmontage Waschbecken / Badewanne - Hoher Durchfluss - ca. 37 l/min
Grifo monomando repisa gran caudal.
Mitigeur pour lavabo/baignoire sur plan avec support de commande à distance high flow.

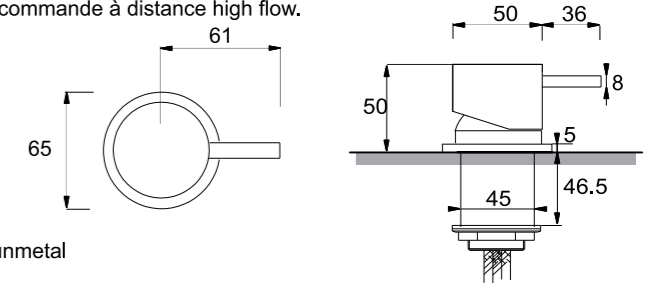

RA -rame/copper bronze GO -british gold GM -nero/gunmetal

IT SA = Satinato LU = Lucido PVD = Colori speciali
DE SA = Satiniert LU = Glänzend PVD = Sonderfarben
EN SA = Satin LU = Polished PVD = Special colour
F SA = Satiniert LU = Poli PVD = Couleurs spéciales

IT SA = Satinato LU = Lucido PVD = Colori speciali
DE SA = Satiniert LU = Glänzend PVD = Sonderfarben
EN SA = Satin LU = Polished PVD = Special colour
F SA = Satiniert LU = Poli PVD = Couleurs spéciales

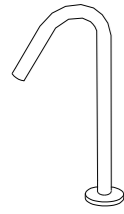

COMPLEMENTS

Bocca lavabo appoggio forma a cigno H 250 mm
 Deck mounted swan-neck basin spout H 250 mm
 Schwanenhalsfoermiger-Auslauf H 250 mm
 Caño repisa en forma de cisne H 250 mm
 Bouche lavabo soutien forme de cygne H 250 mm

RA -rame/copper bronze GO -british gold GM -nero/gunmetal

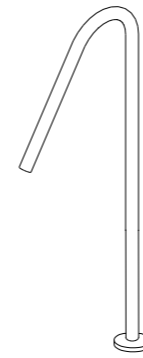
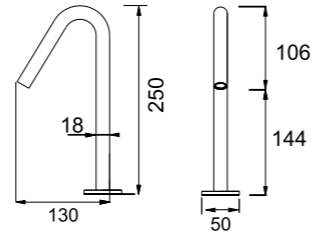

COMPLEMENTS

Bocca lavabo appoggio forma a cigno H 480 mm
 Deck mounted swan-neck basin spout H 480 mm
 Schwanenhalsfoermiger-Auslauf H 480 mm - Ausladung 220 mm
 Caño repisa en forma de cisne H 480 mm
 Bouche lavabo soutien forme de cygne H 480 mm

RA -rame/copper bronze GO -british gold GM -nero/gunmetal

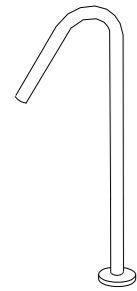
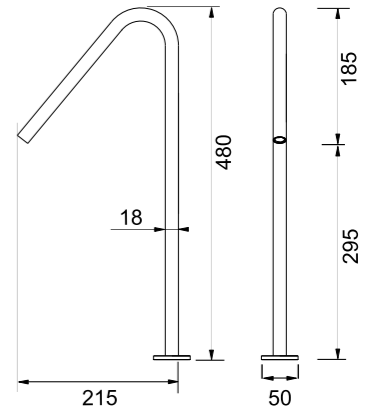

COMPLEMENTS

Bocca lavabo appoggio forma a cigno H 350 mm
 Deck mounted swan-neck basin spout H 350 mm
 Schwanenhalsfoermiger-Auslauf H 350 mm - Ausladung 136 mm
 Caño repisa en forma de cisne H 350 mm
 Bouche lavabo soutien forme de cygne H 350 mm

RA -rame/copper bronze GO -british gold GM -nero/gunmetal

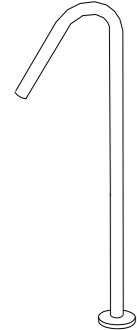
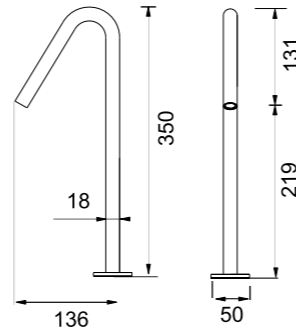

COMPLEMENTS

Bocca lavabo appoggio forma a cigno H 480 mm
 Deck mounted swan-neck basin spout H 480 mm
 Schwanenhalsfoermiger Auslauf H 480 mm - Ausladung 136 mm
 Caño repisa en forma de cisne H 480 mm
 Bouche lavabo soutien forme de cygne H 480 mm

RA -rame/copper bronze GO -british gold GM -nero/gunmetal

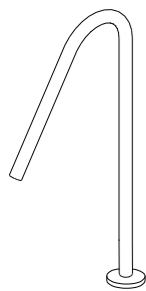
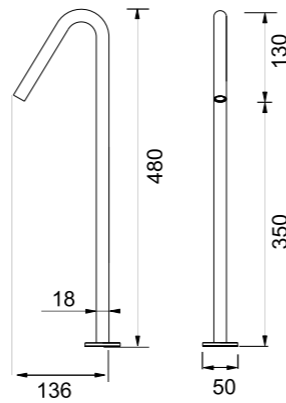

COMPLEMENTS

Bocca lavabo appoggio forma a cigno H 400 mm
 Deck mounted swan-neck basin spout H 400 mm
 Schwanenhalsfoermiger-Auslauf H 400 mm - Ausladung 220 mm
 Caño repisa en forma de cisne H 400 mm
 Bouche lavabo soutien forme de cygne H 400 mm

RA -rame/copper bronze GO -british gold GM -nero/gunmetal

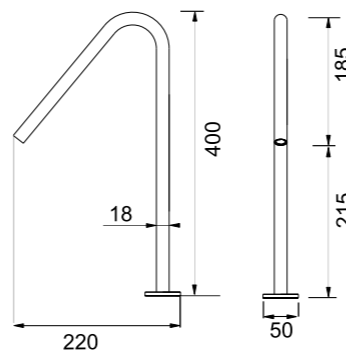

IT SA = Satinato LU = Lucido PVD = Colori speciali
 DE SA = Satiniert LU = Glanzend PVD = Sonderfarben
 EN SA = Satin LU = Polished PVD = Special colour
 F SA = Satinée LU = Poli PVD = Couleurs spéciales

IT SA = Satinato LU = Lucido PVD = Colori speciali
 DE SA = Satiniert LU = Glanzend PVD = Sonderfarben
 EN SA = Satin LU = Polished PVD = Special colour
 F SA = Satinée LU = Poli PVD = Couleurs spéciales

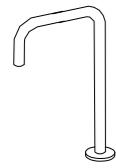

COMPLEMENTS

Bocca lavabo appoggio forma quadra H 250 mm
 Deck mounted square neck basin spout H 250 mm
 U-foermiger Auslauf H 250 mm
 Caño repisa en forma cuadrada H 250 mm
 Bouche lavabo soutien forme carrée H 250 mm

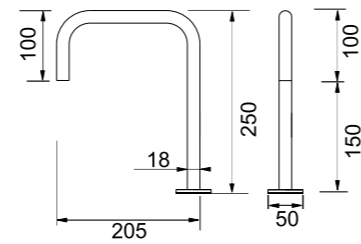

RA -rame/copper bronze GO -british gold GM -nero/gunmetal

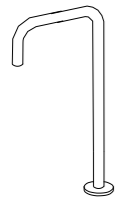

COMPLEMENTS

Bocca lavabo appoggio forma quadra H 300 mm
 Deck mounted square neck basin spout H 300 mm
 U-foermiger Auslauf H 300 mm - Ausladung 205 mm
 Caño repisa en forma cuadrada H 300 mm
 Bouche lavabo soutien forme carrée H 300 mm

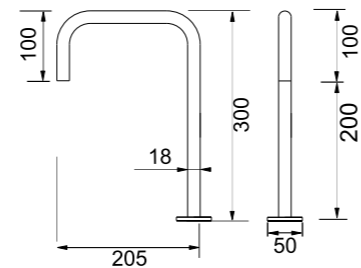

RA -rame/copper bronze GO -british gold GM -nero/gunmetal

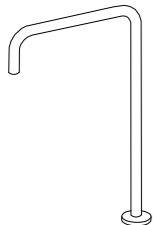

COMPLEMENTS

Bocca lavabo appoggio forma quadra H 350 mm
 Deck mounted square neck basin spout H 350 mm
 U-foermiger Auslauf H 350 mm - Ausladung 280 mm
 Caño repisa en forma cuadrada H 350 mm
 Bouche lavabo soutien forme carrée H 350 mm

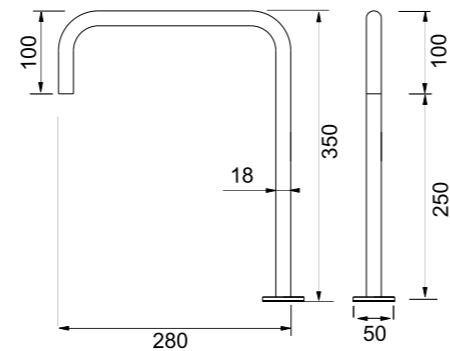

RA -rame/copper bronze GO -british gold GM -nero/gunmetal

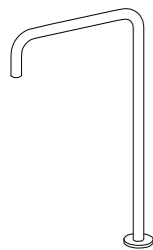

COMPLEMENTS

Bocca lavabo appoggio forma quadra H 400 mm
 Deck mounted square neck basin spout H 400 mm
 U-foermiger Auslauf H 400 mm - Ausladung 280 mm
 Caño repisa en forma cuadrada H 400 mm
 Bouche lavabo soutien forme carrée H 400 mm

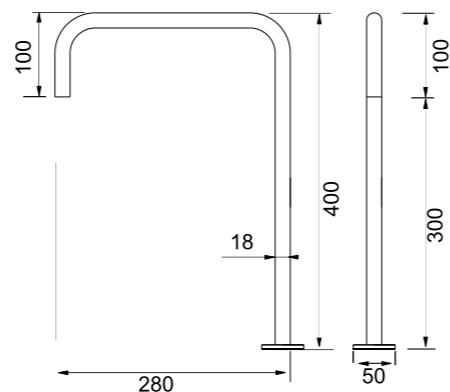

RA -rame/copper bronze GO -british gold GM -nero/gunmetal

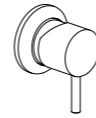

L1

Miscelatore lavabo/bidet incasso a parete «parte esterna»
 Single lever sink mixer basin-bidet outside part, concealed valve not included.
 Wandmischer f. Waschbecken / Bidet
 Grifo monomando de lavabo-bidet parte exterior. No incluye mecanismo empotrado.
 Mitigeur pour lavabo - bidet partie extérieure, sans corps d'encastrement.

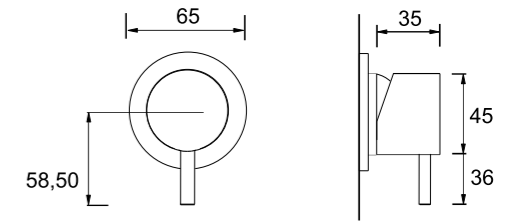

RA -rame/copper bronze GO -british gold GM -nero/gunmetal

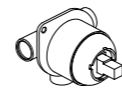

L1

Corpo incasso per art. CO800
 Concealed valve for art. CO800
 Unterputz-Einbauteil f. art. CO800
 Mecanismo empotrado para art. CO800
 Corps d'encastrement pour art. CO800

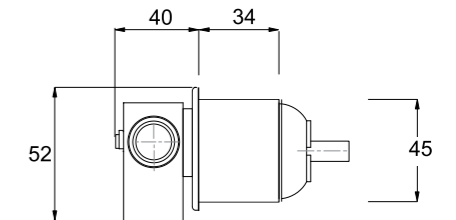

RA -rame/copper bronze GO -british gold GM -nero/gunmetal

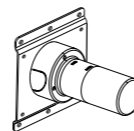

L1

Corpo incasso per art. CO800 con staffa fissaggio
 Concealed valve for art. CO800 with fixing bracket
 Unterputz-Einbauteil f. art. CO800 mit Befestigungsplatte
 Mecanismo empotrado para art. CO800 con soporte de montaje
 Corps d'encastrement pour art. CO800 avec support de montage

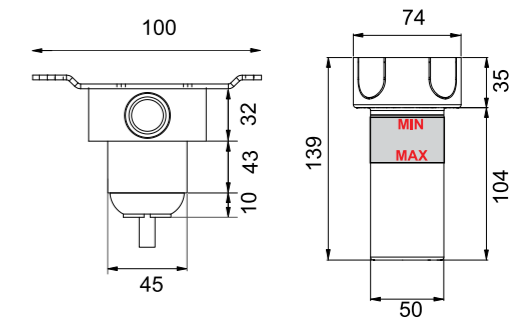

RA -rame/copper bronze GO -british gold GM -nero/gunmetal

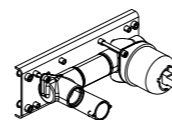

L1

Corpo incasso per art. CO800 e bocche lavabo a parete
 Concealed valve for art. CO800
 Unterputz-Einbauteil f. art. CO800
 Mecanismo empotrado para art. CO800
 Corps d'encastrement pour art. CO800

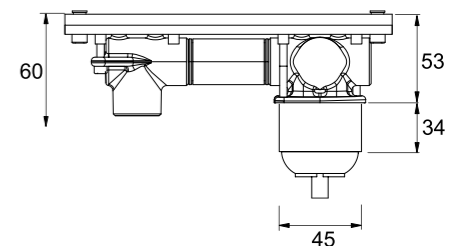

RA -rame/copper bronze GO -british gold GM -nero/gunmetal

IT SA = Satinato LU = Lucido PVD = Colori speciali
 DE SA = Satiniert LU = Glanzend PVD = Sonderfarben
 EN SA = Satin LU = Polished PVD = Special colour
 F SA = Satiniert LU = Poli PVD = Couleurs spéciales

IT SA = Satinato LU = Lucido PVD = Colori speciali
 DE SA = Satiniert LU = Glanzend PVD = Sonderfarben
 EN SA = Satin LU = Polished PVD = Special colour
 F SA = Satiniert LU = Poli PVD = Couleurs spéciales

COMPLEMENTS

Corpo incasso bocche lavabo/bidet/vasca a parete

Concealed valve basin - bidet - tub for wall mount spout.
 Unterputz-Einbauteil f. Wandauslauf mit Befestigungsplatte
 Cuerpo empotrado caño de lavabo - bidé - bañera a pared
 Corps encastré bouches lavabo - bidet - baignoire à mur

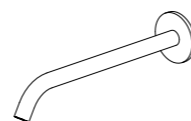
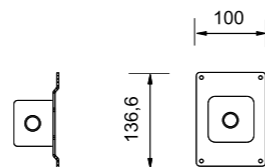

COMPLEMENTS

Bocca lavabo incasso a parete P 250 mm

Wall mount sink spout, concealed valve not included P 250 mm.
 Wandauslauf - Ausladung 250 mm
 Caño a pared, cuerpo empotrado no incluido P 250 mm.
 Bec encastré mural pour lavabo, sans corps d'encastrement P 250 mm.

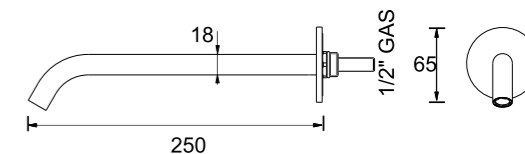

RA -rame/copper bronze GO -british gold GM -nero/gunmetal

COMPLEMENTS

Bocca lavabo incasso a parete P 130 mm

Wall mount sink spout, concealed valve not included P 130 mm.
 Wandauslauf - Ausladung 130 mm
 Caño a pared, cuerpo empotrado no incluido P 130 mm.
 Bec encastré mural pour lavabo, sans corps d'encastrement P 130 mm.

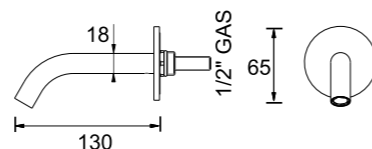

RA -rame/copper bronze GO -british gold GM -nero/gunmetal

L1

Corpo incasso per Miscelatore lavabo/vasca da terra Freestanding

Concealed valve for art. CO105-511
 Einbauteil zu Wannen-, Waschtischstandarmatur mit Befestigungsplatte art. CO105-510
 Mecanismo empotrado para art. CO105-511
 Corps d'encastrement pour art. CO105-511

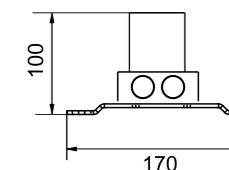
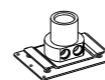

COMPLEMENTS

Bocca lavabo incasso a parete P 160 mm

Wall mount sink spout, concealed valve not included P 160 mm.
 Wandauslauf - Ausladung 160 mm
 Caño a pared, cuerpo empotrado no incluido P 160 mm.
 Bec encastré mural pour lavabo, sans corps d'encastrement P 160 mm.

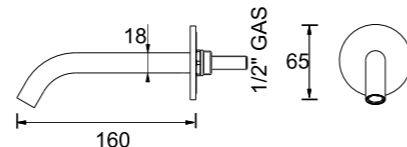

RA -rame/copper bronze GO -british gold GM -nero/gunmetal

L1

Miscelatore lavabo da terra Freestanding

Freestanding single lever sink mixer, concealed valve not included.
 Standarmatur fuer Waschtisch oder Bdewanne - freistehend - H 1060 mm
 Monomando a suelo para lavabo, no incluye mecanismo empotrado.
 Mitigeur pour lavabo à poser au sol sans corps d'encastrement.

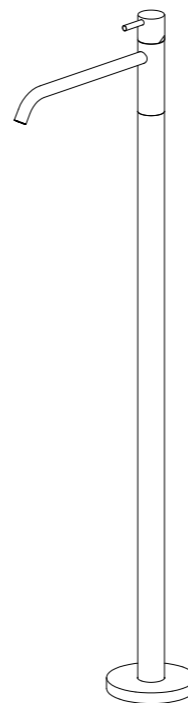

RA -rame/copper bronze GO -british gold GM -nero/gunmetal

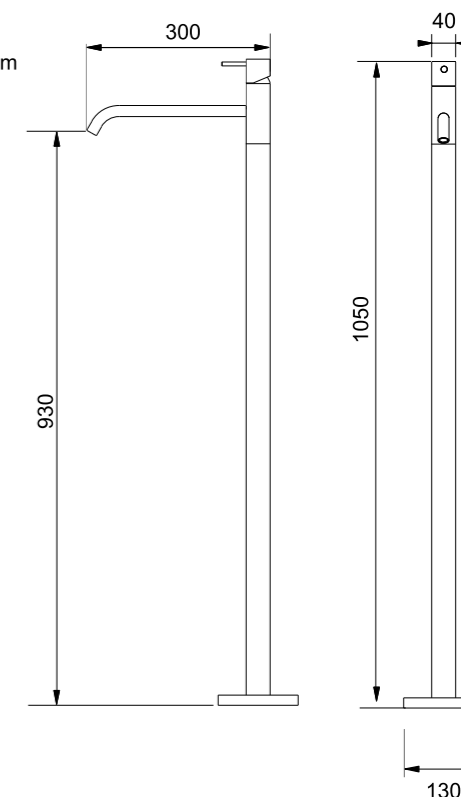

COMPLEMENTS

Bocca lavabo incasso a parete P 200 mm

Wall mount sink spout, concealed valve not included P 200 mm.
 Wandauslauf - Ausladung 200 mm
 Caño a pared, cuerpo empotrado no incluido P 200 mm.
 Bec encastré mural pour lavabo, sans corps d'encastrement P 200 mm.

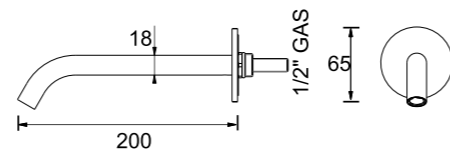
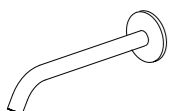

RA -rame/copper bronze GO -british gold GM -nero/gunmetal

IT SA = Satinato LU = Lucido PVD = Colori speciali	DE SA = Satiniert LU = Glaenzend PVD = Sonderfarben	EN SA = Satin LU = Polished PVD = Special colour	F SA = Satinée LU = Poli PVD = Couleurs spéciales
---	--	---	--

IT SA = Satinato LU = Lucido PVD = Colori speciali	DE SA = Satiniert LU = Glaenzend PVD = Sonderfarben	EN SA = Satin LU = Polished PVD = Special colour	F SA = Satinée LU = Poli PVD = Couleurs spéciales
---	--	---	--



L1
Miscelatore bidet appoggio c/snodo H 155 mm
 Single lever mixer for bidet H 155
 Einhebelmischer mit beweglichem Auslauf f. Bidet H 155 mm
 Grifo monomando para bidè H 155 mm
 Mitigeur pour bidet orientable H 155 mm

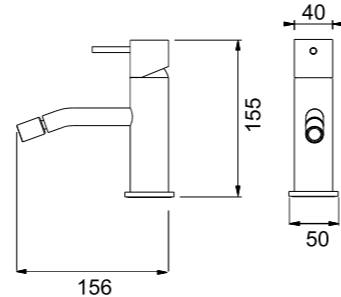

RA -rame/copper bronze GO -british gold GM -nero/gunmetal

COMPLEMENTS

Bocca a parete con erogazione orientabile P 175 mm
 Wall mounted adjustable spout P 175 mm.
 Wandauslauf - Ausladung 175 mm
 Caño mural orientable P 175 mm.
 Bec mural orientable P 175 mm.

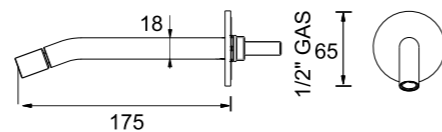
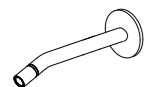

RA -rame/copper bronze GO -british gold GM -nero/gunmetal

COMPLEMENTS

Bocca erogazione orientabile da piano H 115 mm
 Deck mounted adjustable spout H 115 mm.
 Beweglicher Platteeinbau Auslauf H 115 mm.
 Caño orientable de repisa H 115 mm.
 Bec orientable sur plan H 115 mm.

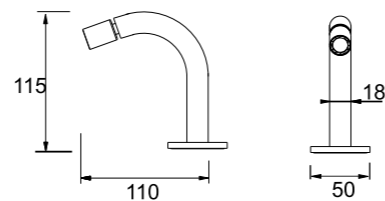

RA -rame/copper bronze GO -british gold GM -nero/gunmetal

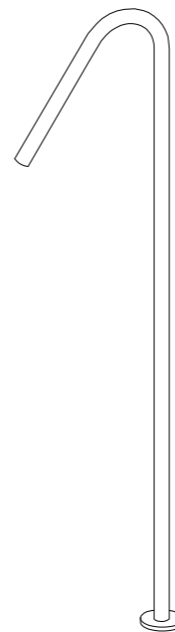

COMPLEMENTS

Canna erogazione lavabo da terra forma a cigno H 1140 mm
 Freestanding sink - tub spout H 1140 mm
 Schwanenhalsfoermiger freistehender Auslauf H 1140 mm - Ausladung 220 mm
 Caño a suelo H 1140 mm
 Bec d'écoulement au sol pour lavabo - baignoire en forme de cygne H 1140 mm

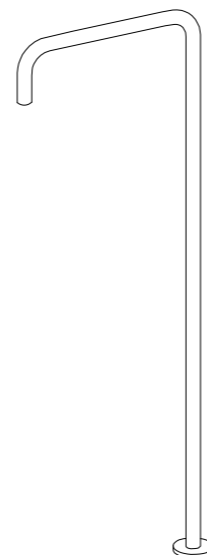
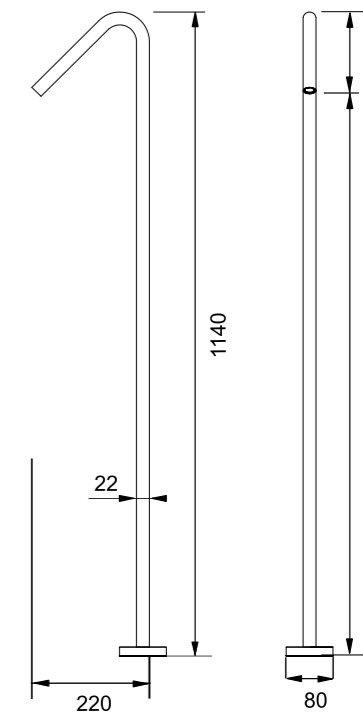

COMPLEMENTS

Canna erogazione lavabo da terra forma quadra H 1060 mm
 Freestanding sink spout H 1060 mm
 U-foermiger freistehender Auslauf H 1060 mm - Ausladung 315 mm
 Caño a suelo H 1060 mm
 Bec d'écoulement au sol pour lavabo - baignoire en forme carrée H 1060 mm

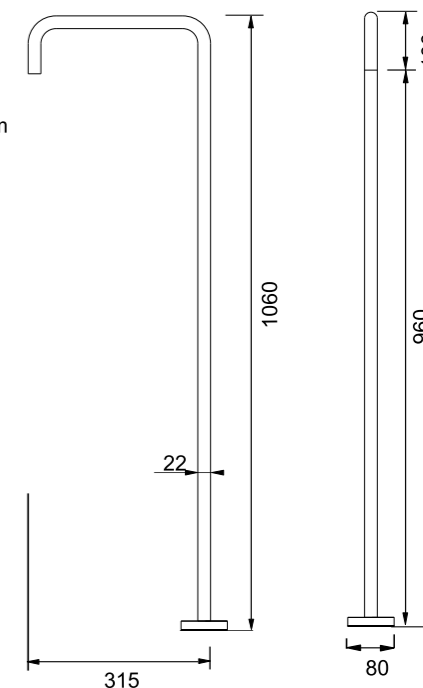

COMPLEMENTS

Corpo incasso bocche lavabo/bidet/vasca a parete
 Concealed valve basin - bidet - tub for wall mount spout.
 Unterputz-Einbauteil f. Wandauslauf mit Befestigungsplatte
 Cuerpo empotrado caño de lavabo - bidè - bañera a pared
 Corps encastré bouches lavabo - bidet - baignoire à mur

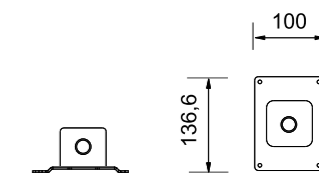

IT
 SA = Satinato
 LU = Lucido
 PVD = Colori speciali

DE
 SA = Satiniert
 LU = Glaenzend
 PVD = Sonderfarben

EN
 SA = Satin
 LU = Polished
 PVD = Special colour

F
 SA = Satinée
 LU = Poli
 PVD = Couleurs spéciales

IT
 SA = Satinato
 LU = Lucido
 PVD = Colori speciali

DE
 SA = Satiniert
 LU = Glaenzend
 PVD = Sonderfarben

EN
 SA = Satin
 LU = Polished
 PVD = Special colour

F
 SA = Satinée
 LU = Poli
 PVD = Couleurs spéciales



COMPLEMENTS

Piletta chiusura a pressione in ABS con rivestimento coperchio in acciaio inox

Drain pipe fitting with pressure plug in ABS finished in stainless steel.
 Push-Up Ablaufgarnitur aus ABS (Edelstahl-Optik oder Hockglanzchrom-Optik) f. Waschbecken und Bidet
 Válvula de desague a presión clik-clak en ABS, acabado en cromo brillo o acero satinado
 Raccord complet avec vidage à pression clik-clak en ABS chromé brillant ou acier satiné

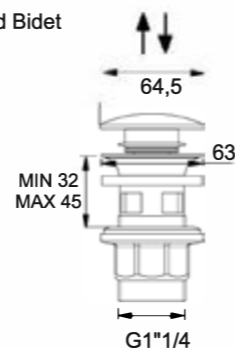

COMPLEMENTS

Piletta chiusura a pressione in ABS con rivestimento coperchio in acciaio inox

Drain pipe fitting with pressure plug in ABS finished in stainless steel.
 Push-Up Ablaufgarnitur aus ABS (Edelstahl-Optik oder Hockglanzchrom-Optik) f. Waschbecken und Bidet
 Válvula de desague a presión clik-clak en ABS, acabado en cromo brillo o acero satinado
 Raccord complet avec vidage à pression clik-clak en ABS chromé brillant ou acier satiné

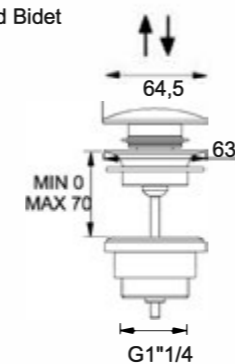

COMPLEMENTS

Piletta chiusura a pressione totalmente in acciaio inox

Drain pipe fitting with pressure plug in stainless steel.
 Ablaufventil mit Klickverschluss für Waschbecken und Bidet. Stöpsel und Körper aus Edelstahl AISI 316.
 Válvula de desague a presión clik-clak en acero.
 Raccord complet avec vidage à pression clik-clak en acier.

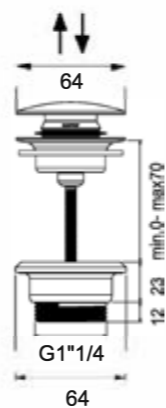

RA -rame/copper bronze GO -british gold GM -nero/gunmetal

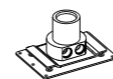

L1

Corpo incasso per Miscelatore lavabo/vasca da terra Freestanding

Concealed valve for art. CO105-511
 Einbauteil zu Wannen-, Waschtischstandarmatur mit Befestigungsplatte art. CO105-511
 Mecanismo empotrado para art. CO105-511
 Corps d'encastrement pour art. CO105-511

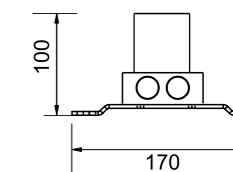

L1

Colonna vasca da terra «freestanding» completa ALTA PORTATA

Freestanding bath mixer complete «HIGH FLOW»
 Freistehende Badewannenarmatur mit hohem Durchfluss und Handbrause
 Columna a suelo para bañera alto flujo
 Colonne pour baignoire high flow

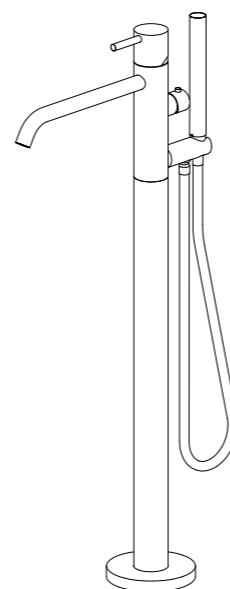

RA -rame/copper bronze GO -british gold GM -nero/gunmetal

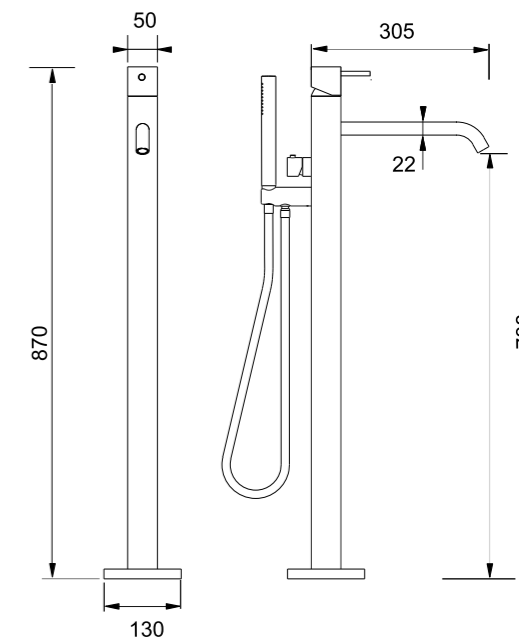

IT	DE	EN	F
SA = Satinato	SA = Satiniert	SA = Satin	SA = Satinée
LU = Lucido	LU = Glanzend	LU = Polished	LU = Poli
PVD = Colori speciali	PVD = Sonderfarben	PVD = Special colour	PVD = Couleurs spéciales

IT	DE	EN	F
SA = Satinato	SA = Satiniert	SA = Satin	SA = Satinée
LU = Lucido	LU = Glanzend	LU = Polished	LU = Poli
PVD = Colori speciali	PVD = Sonderfarben	PVD = Special colour	PVD = Couleurs spéciales



L1
Termostatico coassiale con apertura/chiusura acqua doccia/vasca incasso a parete «parte esterna»
 Coaxial thermostatic mixer with command handle. Concealed valve not included.
 Wandthermostataarmatur f. Wannen/Dusche
 Grifo termostático coaxial con apertura y cierre de caudal no incluye mecanismo empotrado
 Mitigeur thermostatique coaxial mural avec ouverture et fermeture eau, sans corps d'encastrement

RA -rame/copper bronze GO -british gold GM -nero/gunmetal

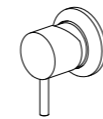
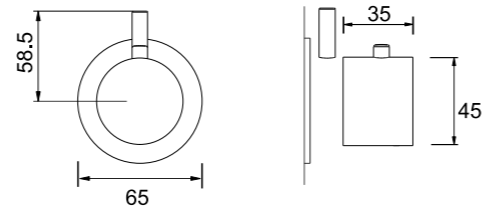

L1
Miscelatore doccia/vasca incasso a parete «parte esterna»
 Single lever shower/tub mixer part only for wall encasing, concealed valve not included
 Wandmischer f. Wannen
 Grifo monomando de ducha para encastre a pared, no incluye mecanismo empotrado.
 Mitigeur mural pour douche, sans corps d'encastrement.

RA -rame/copper bronze GO -british gold GM -nero/gunmetal

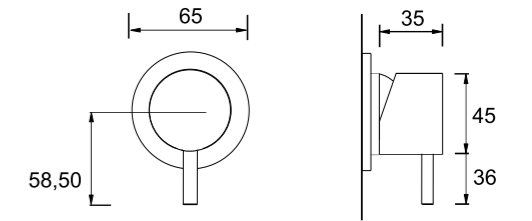

L1
Corpo incasso per art. CO902
 Concealed valve for art. CO902
 Unterputz-Einbauteil f. Art. CO902
 Mecanismo empotrado para art. CO902
 Corps d'encastrement pour art. CO902

RA -rame/copper bronze GO -british gold GM -nero/gunmetal

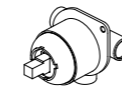
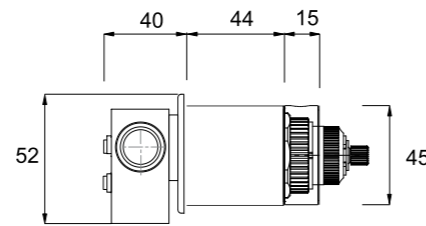

L1
Corpo incasso per art. CO810
 Concealed valve for art. CO810
 Unterputz-Einbauteil f. Art. CO810
 Mecanismo empotrado para art. CO810
 Corps d'encastrement pour art. CO810

RA -rame/copper bronze GO -british gold GM -nero/gunmetal

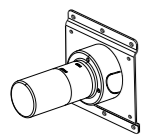
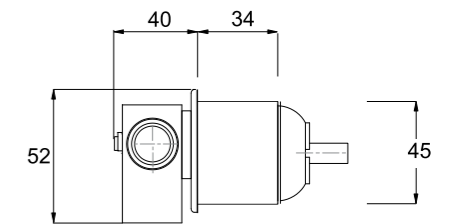

L1
Corpo incasso per art. CO902 c/staffa di fissaggio
 Concealed valve for art. CO902
 Unterputz-Einbauteil f. Art. CO902 mit Befestigungsplatte
 Mecanismo empotrado para art. CO902
 Corps d'encastrement pour art. CO902

RA -rame/copper bronze GO -british gold GM -nero/gunmetal

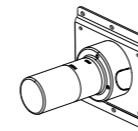
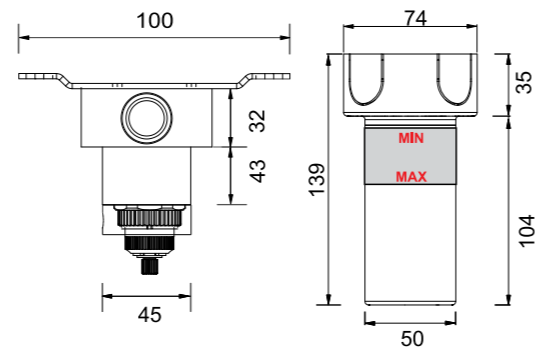

L1
Corpo incasso per art. CO810 c/staffa di fissaggio
 Concealed valve for art. CO810
 Unterputz-Einbauteil f. Art. CO810 mit Befestigungsplatte
 Mecanismo empotrado para art. CO810
 Corps d'encastrement pour art. CO810

RA -rame/copper bronze GO -british gold GM -nero/gunmetal

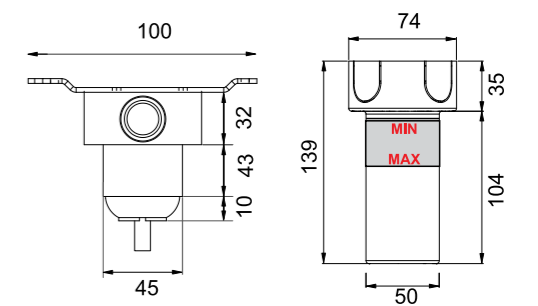

IT	DE	EN	F
SA = Satinato	SA = Satiniert	SA = Satin	SA = Satinée
LU = Lucido	LU = Glänzend	LU = Polished	LU = Poli
PVD = Colori speciali	PVD = Sonderfarben	PVD = Special colour	PVD = Couleurs spéciales

IT	DE	EN	F
SA = Satinato	SA = Satiniert	SA = Satin	SA = Satinée
LU = Lucido	LU = Glänzend	LU = Polished	LU = Poli
PVD = Colori speciali	PVD = Sonderfarben	PVD = Special colour	PVD = Couleurs spéciales

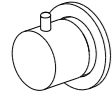

L1

Maniglia per deviatore doccia/vasca incasso a parete «parte esterna»

Diverter shower/tub recessed wall «outside part»
Griff f. Umsteller
Desviador ducha/bañera empotrada en la pared «parte externo»
Déviateur douche/baignoire encastré au mur «partie extérieure»

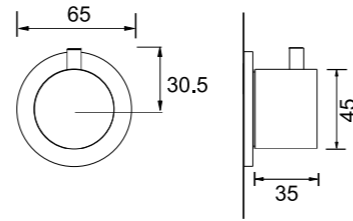

RA -rame/copper bronze GO -british gold GM -nero/gunmetal

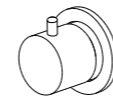

L1

Maniglia per deviatore doccia/vasca incasso a parete «parte esterna»

Diverter shower/tub recessed wall «outside part»
Griff f. Umsteller
Desviador ducha/bañera empotrada en la pared «parte externo»
Déviateur douche/baignoire encastré au mur «partie extérieure»

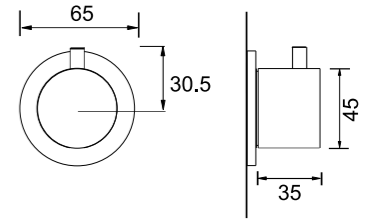

RA -rame/copper bronze GO -british gold GM -nero/gunmetal



L1

Corpo incasso deviatore 2 vie per art. CO900 SENZA CHIUSURA

Concealed valve 2 way diverter for art. CO900
Unterputz-Einbauteil f. Zweiwegeumstellung Art. CO900 mit Befestigungsplatte
Mecanismo empotrado 2 vias desviador para art. CO900
Corps d'encastrement déviateur 2 voies pour art. CO900 sans fermeture

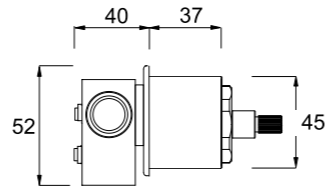

RA -rame/copper bronze GO -british gold GM -nero/gunmetal

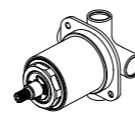

L1

Corpo incasso deviatore 3 vie per art. CO900 SENZA CHIUSURA

Concealed valve 3 way diverter for art. CO900
Unterputz-Einbauteil f. Dreiwegeumstellung Art. CO900
Mecanismo empotrado 3 vias desviador para art. CO900
Corps d'encastrement déviateur 3 voies pour art. CO900

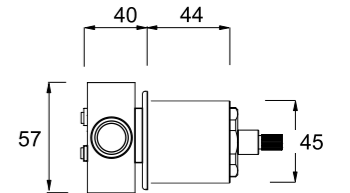

RA -rame/copper bronze GO -british gold GM -nero/gunmetal

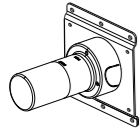

L1

Corpo incasso deviatore 2 vie per art. CO900 c/staffa di fissaggio SENZA CHIUSURA

Concealed valve 2 way diverter for art. CO900
Unterputz-Einbauteil f. Zweiwegeumstellung Art. CO900 mit Befestigungsplatte
Mecanismo empotrado 2 vias desviador para art. CO900
Corps d'encastrement déviateur 2 voies pour art. CO900 avec support de fixation

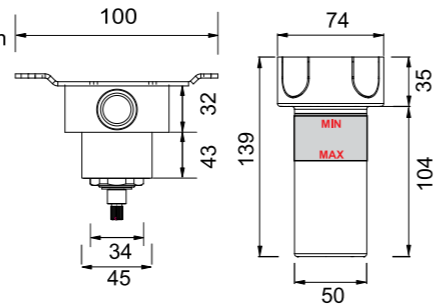

RA -rame/copper bronze GO -british gold GM -nero/gunmetal

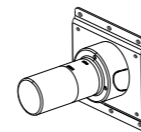

L1

Corpo incasso deviatore 3 vie per art. CO900 c/staffa di fissaggio SENZA CHIUSURA

Concealed valve 3 way diverter for art. CO900
Unterputz-Einbauteil f. Dreiwegeumstellung Art. CO900 mit Befestigungsplatte
Mecanismo empotrado 3 vias desviador para art. CO900
Corps d'encastrement déviateur 3 voies pour art. CO900

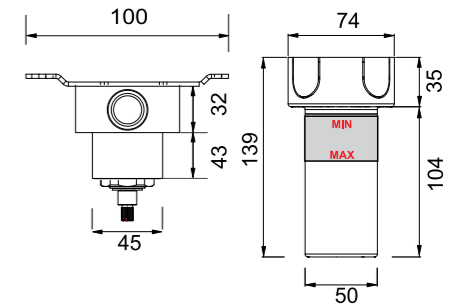

RA -rame/copper bronze GO -british gold GM -nero/gunmetal

IT SA = Satinato LU = Lucido PVD = Colori speciali
DE SA = Satiniert LU = Glaenzend PVD = Sonderfarben
EN SA = Satin LU = Polished PVD = Special colour
F SA = Satinée LU = Poli PVD = Couleurs spéciales

IT SA = Satinato LU = Lucido PVD = Colori speciali
DE SA = Satiniert LU = Glaenzend PVD = Sonderfarben
EN SA = Satin LU = Polished PVD = Special colour
F SA = Satinée LU = Poli PVD = Couleurs spéciales

COMPLEMENTS

Bocca erogazione vasca incasso a parete D. 27 P. 200 mm

Wall mount bath spout D. 27 P.200 mm
Wandauslauf - Durchmesser 27 mm - Ausladung 200 mm
Caño de bañera de pared D. 27 P.200 mm
Bec baignoire mur D.27 P.200 mm

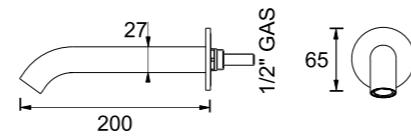

RA -rame/copper bronze GO -british gold GM -nero/gunmetal

COMPLEMENTS

Bocca erogazione vasca incasso a parete D. 27 P. 250 mm

Wall mount bath spout D. 27 P.250 mm
Wandauslauf - Durchmesser 27 mm - Ausladung 250 mm
Caño de bañera de pared D. 27 P.250 mm
Bec baignoire mur D.27 P.250 mm

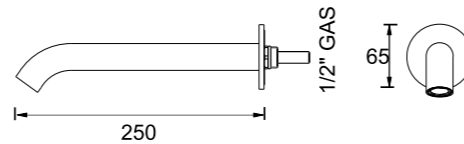

RA -rame/copper bronze GO -british gold GM -nero/gunmetal

COMPLEMENTS

Corpo incasso bocche lavabo/bidet/vasca a parete

Concealed valve basin - bidet - tub for wall mount spout.
Unterputz-Einbauteil f. Wandauslauf mit Befestigungsplatte
Cuerpo empotrada bocas lavabo - bidet - banera a pared
Corps encastré bouches lavabo - bidet - baignoire à mur

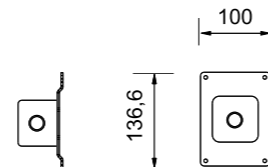

IT
SA = Satinato
LU = Lucido
PVD = Colori speciali

DE
SA = Satiniert
LU = Glaenzend
PVD = Sonderfarben

EN
SA = Satin
LU = Polished
PVD = Special colour

F
SA = Satinée
LU = Poli
PVD = Couleurs spéciales

L1

Miscelatore lavabo/vasca appoggio comando remoto alta portata

Deck mounted single lever basin mixer high flow
Einheblmischer f. Standmontage Waschbecken / Badewanne - Hoher Durchfluss - ca. 37 l/min
Grifo monomando repisa gran caudal.
Mitigeur pour lavabo support de commande à distance high flow.

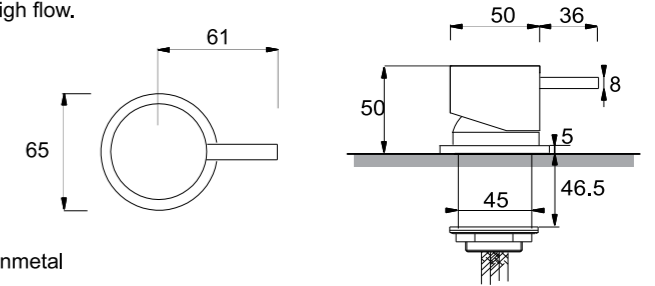
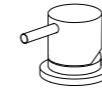

RA -rame/copper bronze GO -british gold GM -nero/gunmetal

COMPLEMENTS

Canna erogazione bordo vasca forma cigno Ø 27 H 350 mm

Cane dispensing tubside swan shape D. 27 H 350 mm
Schwanenhalsfoermiger-Auslauf f. Wannenrand H 350 mm Durchm. 27 mm
Caño bañera forma de cisne D. 27 H 350 mm
Canne bord baignoire forme de cygne D. 27 H 350 mm

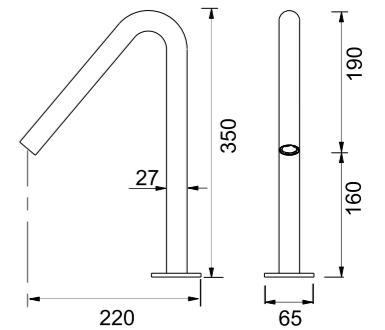
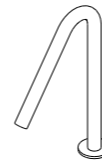

RA -rame/copper bronze GO -british gold GM -nero/gunmetal

COMPLEMENTS

Canna erogazione bordo vasca forma quadra Ø 27 H 280 mm

Cane dispensing tubside square shape D. 27 H 280 mm
U-foermiger Auslauf f. Wannenrand - Durchm. 27 mm H 280 mm
Caño bañera forma cuadrada D. 27 H 280 mm
Canne bord baignoire forme carrée D. 27 H 280 mm

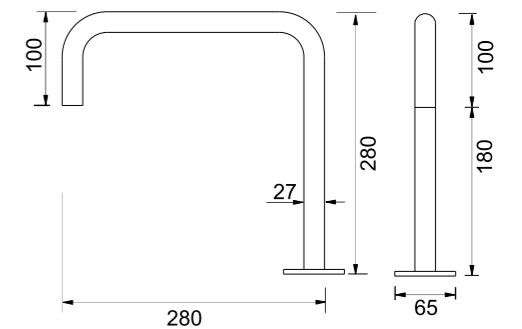

RA -rame/copper bronze GO -british gold GM -nero/gunmetal

IT
SA = Satinato
LU = Lucido
PVD = Colori speciali

DE
SA = Satiniert
LU = Glaenzend
PVD = Sonderfarben

EN
SA = Satin
LU = Polished
PVD = Special colour

F
SA = Satinée
LU = Poli
PVD = Couleurs spéciales



COMPLEMENTS

Canna erogazione vasca da pavimento forma a cigno H 940 mm
 Cane bathtub floor swan shape H 940 mm
 Schwanenhalsfoermiger freistehender Auslauf H 940 mm Durchm. 27 mm
 Caño bañera forma de cisne H 940 mm
 Roseau baignoire sol en forme de cygne H 940 mm

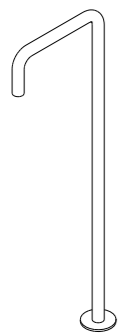
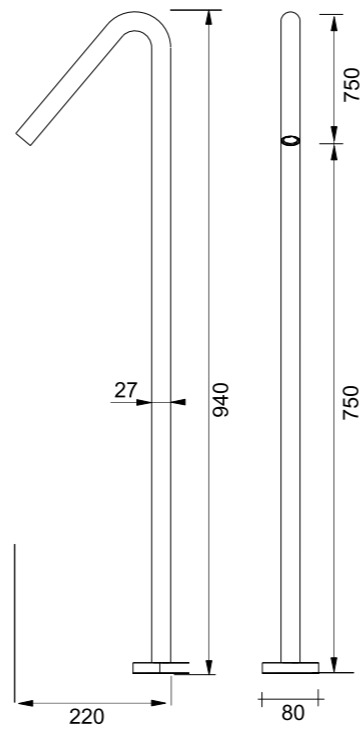

COMPLEMENTS

Canna erogazione vasca da pavimento forma quadra H 865 mm
 Cane bathtub floor square shape H 865 mm
 U-foermiger freistehender Auslauf H 865 mm Durchm.
 Caño bañera forma cuadrada H 865 mm
 Roseau baignoire sol forme carrée H 865 mm

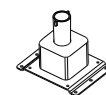
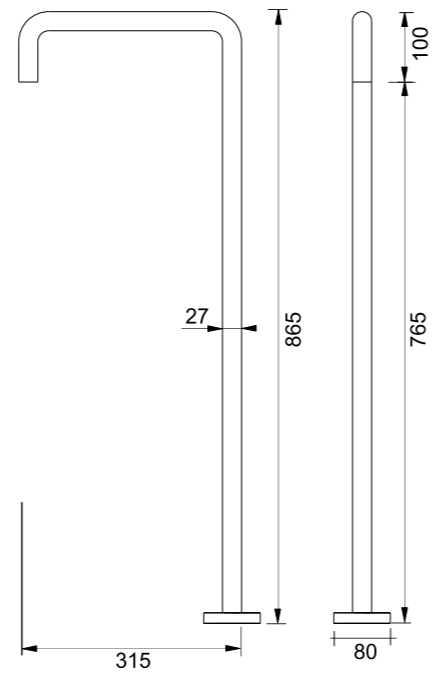

COMPLEMENTS

Corpo incasso bocche lavabo/bidet/vasca a parete
 Concealed valve basin - bidet - tub for wall mount spout.
 Unterputz-Einbauteil f. Wandauslauf mit Befestigungsplatte
 Cuerpo empotrado caño de lavabo - bidé - bañera a pared
 Corps encastré bouches lavabo - bidet - baignoire à mur

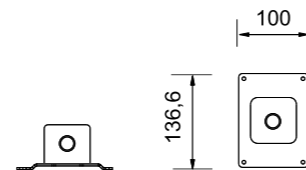

IT	DE	EN	F
SA = Satinato	SA = Satiniert	SA = Satin	SA = Satinée
LU = Lucido	LU = Glaenzend	LU = Polished	LU = Poli
PVD = Colori speciali	PVD = Sonderfarben	PVD = Special colour	PVD = Couleurs spéciales

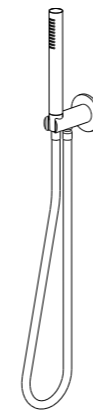

COMPLEMENTS

Doccetta a stilo completa attacco a parete c/flessibile a molla inox
 Shower hand complete wall connection
 Handbrause komplett mit Wandbefestigung
 Ducha completa con montaje en pared
 Douche complète avec support mural et flexible à ressort en inox

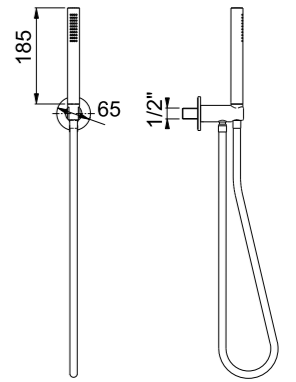

COMPLEMENTS

Doccetta a stilo completa attacco a parete c/flessibile silicone
 Shower hand complete wall connection
 Handbrause komplett mit Wandbefestigung
 Ducha completa con montaje en pared
 Douche complète avec support mural et flexible en silicone

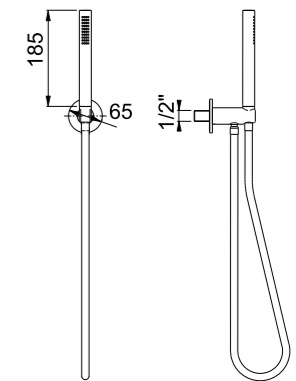

RA -rame/copper bronze GO -british gold GM -nero/gunmetal

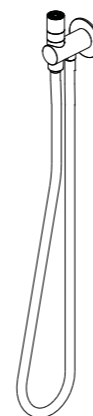

COMPLEMENTS

Doccetta a parete DUPLEX completa di flessibile inox
 Shower hand complete wall connection
 Handbrause komplett mit Wandbefestigung
 Ducha completa con montaje en pared
 Douche complète avec support mural et flexible en inox

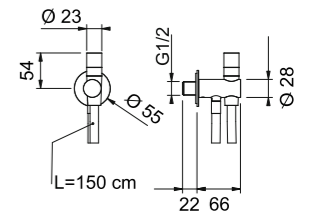

IT	DE	EN	F
SA = Satinato	SA = Satiniert	SA = Satin	SA = Satinée
LU = Lucido	LU = Glaenzend	LU = Polished	LU = Poli
PVD = Colori speciali	PVD = Sonderfarben	PVD = Special colour	PVD = Couleurs spéciales

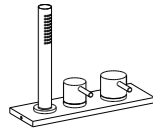

L1
Gruppo bordo vasca c/doccetta estraibile
 Group tubside with shower hand extractable
 3 Wannenrandmischer mit herausnehmbarer Handbrause
 Grupo junto a la bañera con ducha extraíble
 Groupe baignoire avec douche extractible

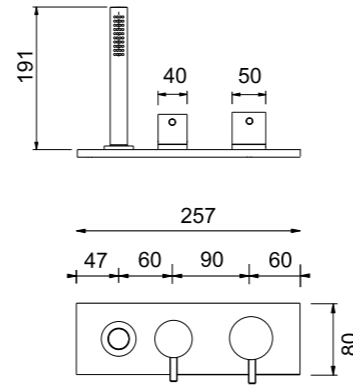

RA -rame/copper bronze GO -british gold GM -nero/gunmetal

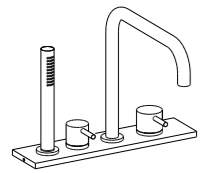

L1
Gruppo bordo vasca c/erogazione e doccetta estraibile
 Group tubside with spout shower hand extractable
 3 Wannenrandmischer mit herausnehmbarer Handbrause und U-foermiger Auslauf
 Grupo junto a la bañera con ducha extraíble
 Groupe baignoire avec bec et douche extractible

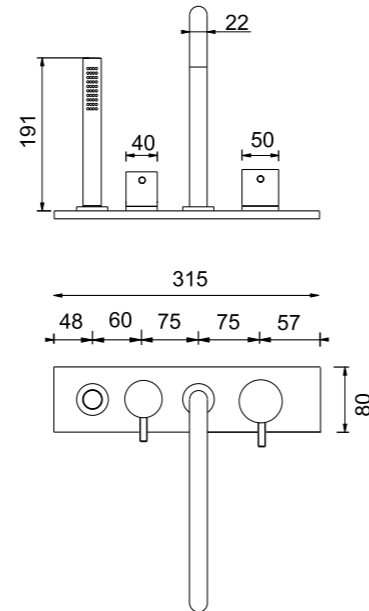

RA -rame/copper bronze GO -british gold GM -nero/gunmetal

COMPLEMENTS

Soffione doccia cilindrico 200 mm
 Shower head cylindrical 200 mm
 Regendusche Durchm. 200 mm mit Entkalkungssystem
 Rociador ducha cilindrico 200 mm
 Tête de douche cylindrique 200 mm

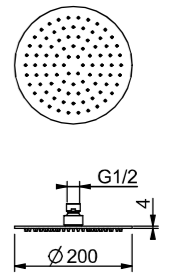

RA -rame/copper bronze GO -british gold GM -nero/gunmetal

COMPLEMENTS

Soffione doccia cilindrico 250 mm
 Shower head cylindrical 250 mm
 Regendusche Durchm. 250 mm mit Entkalkungssystem
 Rociador ducha cilindrico 250 mm
 Tête de douche cylindrique 250 mm

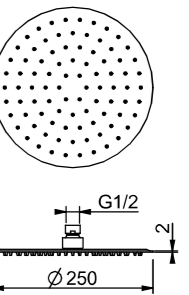

COMPLEMENTS

Soffione doccia cilindrico 300 mm
 Shower head cylindrical 300 mm
 Regendusche Durchm. 300 mm mit Entkalkungssystem
 Rociador ducha cilindrico 300 mm
 Tête de douche cylindrique 300 mm

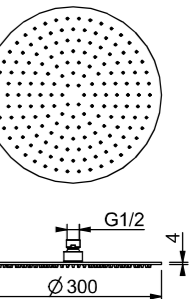

RA -rame/copper bronze GO -british gold GM -nero/gunmetal

COMPLEMENTS

Soffione doccia cilindrico 400 mm
 Shower head cylindrical 400 mm
 Regendusche Durchm. 400 mm mit Entkalkungssystem
 Rociador ducha cilindrico 400 mm
 Tête de douche cylindrique 400 mm

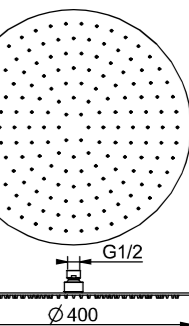

IT	DE	EN	F
SA = Satinato	SA = Satiniert	SA = Satin	SA = Satinée
LU = Lucido	LU = Glanzend	LU = Polished	LU = Poli
PVD = Colori speciali	PVD = Sonderfarben	PVD = Special colour	PVD = Couleurs spéciales

IT	DE	EN	F
SA = Satinato	SA = Satiniert	SA = Satin	SA = Satinée
LU = Lucido	LU = Glanzend	LU = Polished	LU = Poli
PVD = Colori speciali	PVD = Sonderfarben	PVD = Special colour	PVD = Couleurs spéciales

COMPLEMENTS

Soffione doccia quadrato 200x200 mm
Shower head square 200x200 mm
Regendusche 200x200 mm mit Entkalkungssystem
Rociador ducha cuadrado 200x200 mm
Tête de douche carré 200x200 mm

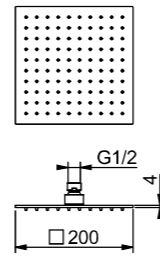

RA -rame/copper bronze GO -british gold GM -nero/gunmetal

COMPLEMENTS

Soffione doccia quadrato 250x250 mm
Shower head square 250x250 mm
Regendusche 250x250 mm mit Entkalkungssystem
Rociador ducha cuadrado 250x250 mm
Tête de douche carré 250x250 mm

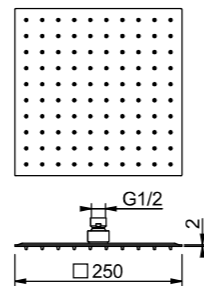

COMPLEMENTS

Soffione doccia quadrato 300x300 mm
Shower head square 300x300 mm
Regendusche 300x300 mm mit Entkalkungssystem
Rociador ducha cuadrado 300x300 mm
Tête de douche carré 300x300 mm

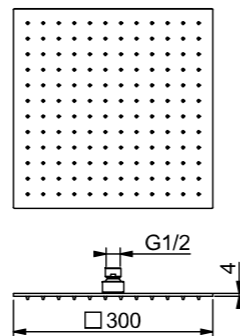

RA -rame/copper bronze GO -british gold GM -nero/gunmetal

COMPLEMENTS

Soffione doccia quadrato 400x400 mm
Shower head square 400x400 mm
Regendusche 400x400 mm mit Entkalkungssystem
Rociador ducha cuadrado 400x400 mm
Tête de douche carré 400x400 mm

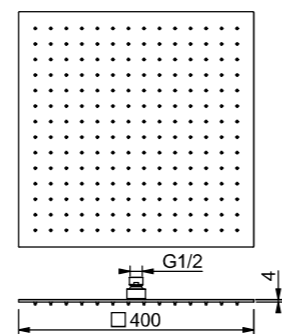

RA -rame/copper bronze GO -british gold GM -nero/gunmetal

IT	DE	EN	F
SA = Satinato	SA = Satiniert	SA = Satin	SA = Satinée
LU = Lucido	LU = Glanzend	LU = Polished	LU = Poli
PVD = Colori speciali	PVD = Sonderfarben	PVD = Special colour	PVD = Couleurs spéciales

COMPLEMENTS

Soffione doccia rettangolare 220x340 mm
Shower head rectangular 220x340 mm
Regendusche rechteckig 220x340 mm mit Entkalkungssystem
Rociador ducha rectangular 220x340 mm
Tête de douche rectangulaire 220x340 mm

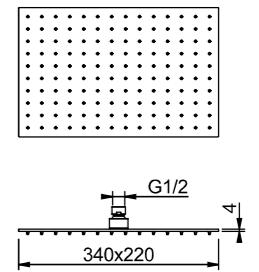

COMPLEMENTS

Soffione doccia rettangolare 300x450 mm
Shower head rectangular 300x450 mm
Regendusche rechteckig 300x450 mm mit Entkalkungssystem
Rociador ducha rectangular 300x450 mm
Tête de douche rectangulaire 300x450 mm

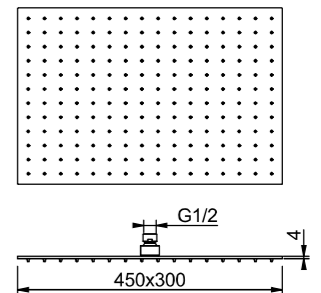

COMPLEMENTS

Soffione doccia rettangolare c/angoli raggiati 220x340 mm
Shower head rectangular with rounded corners 220x340 mm
Regendusche rechteckig 220x340 mm mit abgerundeten Ecken und Entkalkungssystem
Rociador ducha rectangular con esquinas redondeadas 220x340 mm
Tête de douche rectangulaire avec coins arrondis 220x340 mm

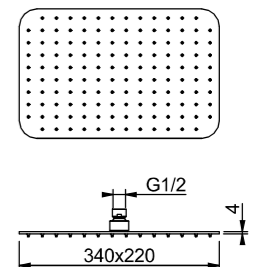

COMPLEMENTS

Soffione doccia rettangolare c/angoli raggiati 300x450 mm
Shower head rectangular with rounded corners 300x450 mm
Regendusche rechteckig 300x450 mm mit abgerundeten Ecken und Entkalkungssystem
Rociador ducha rectangular con esquinas redondeadas 300x450 mm
Tête de douche rectangulaire avec coins arrondis 300x450 mm

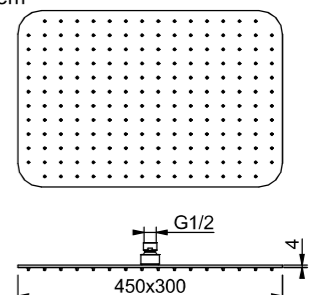

IT	DE	EN	F
SA = Satinato	SA = Satiniert	SA = Satin	SA = Satinée
LU = Lucido	LU = Glanzend	LU = Polished	LU = Poli
PVD = Colori speciali	PVD = Sonderfarben	PVD = Special colour	PVD = Couleurs spéciales

COMPLEMENTS

Braccio a parete per soffione doccia L. 350 mm

Wall arm for shower head L. 350 mm
 Duscharm f. Wandmontage Laenge 350 mm
 Brazo de pared para rociador ducha L. 350 mm
 Bras mural pour la tête de douche L. 350 mm

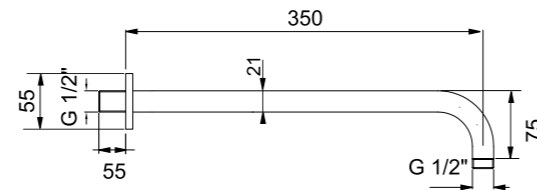

RA -rame/copper bronze GO -british gold GM -nero/gunmetal

COMPLEMENTS

Braccio a soffitto per soffione doccia L. 100 mm

Ceiling arm for shower head L. 100 mm
 Duscharm f. Deckenmontage Laenge 100 mm
 Brazo cielo raso para rociador ducha L. 100 mm
 Bras de plafond pour la tête de douche L. 100 mm

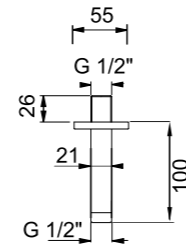

RA -rame/copper bronze GO -british gold GM -nero/gunmetal

COMPLEMENTS

Braccio a soffitto per soffione doccia L. 200 mm

Ceiling arm for shower head L. 200 mm
 Duscharm f. Deckenmontage Laenge 200 mm
 Brazo cielo raso para rociador ducha L. 200 mm
 Bras de plafond pour la tête de douche L. 200 mm

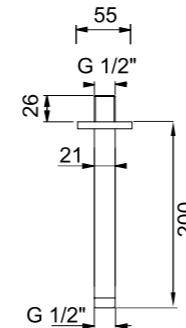

RA -rame/copper bronze GO -british gold GM -nero/gunmetal

COMPLEMENTS

Braccio a soffitto per soffione doccia L. 300 mm

Ceiling arm for shower head L. 300 mm
 Duscharm f. Deckenmontage Laenge 300 mm
 Brazo cielo raso para rociador ducha L. 300 mm
 Bras de plafond pour la tête de douche L. 300 mm

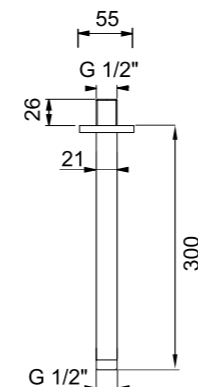

RA -rame/copper bronze GO -british gold GM -nero/gunmetal

IT	DE	EN	F
SA = Satinato	SA = Satiniert	SA = Satin	SA = Satinée
LU = Lucido	LU = Glaenzend	LU = Polished	LU = Poli
PVD = Colori speciali	PVD = Sonderfarben	PVD = Special colour	PVD = Couleurs spéciales

COMPLEMENTS

Braccio a soffitto per soffione doccia L. 400 mm

Ceiling arm for shower head L. 400 mm
 Duscharm f. Deckenmontage Laenge 400 mm
 Brazo a techo para rociador ducha L. 400 mm
 Bras de plafond pour la tête de douche L. 400 mm

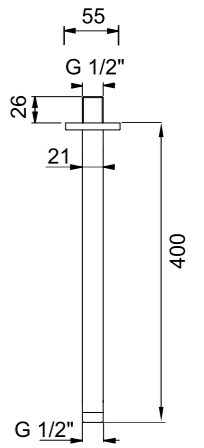

RA -rame/copper bronze GO -british gold GM -nero/gunmetal

COMPLEMENTS

Soffione doccia rettangolare attacco a parete 500x160 mm

Shower head rectangular wall mount 500x160 mm
 Kopfbrause 500x160 mm - mit direkter Wandbefestigung
 Rociador ducha rectangular montaje en pared 500x160 mm
 Tête de douche rectangulaire attaque mur 500x160 mm

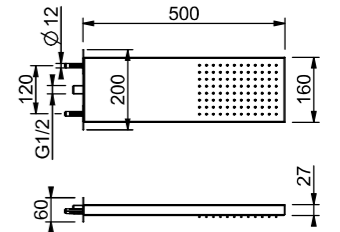

COMPLEMENTS

Soffione doccia rettangolare attacco a parete c/cascata acqua 500x160 mm

Shower head rectangular wall mount with waterfall water 500x160 mm
 Kopfbrause mit Schwalldusche 500x160 mm - mit direkter Wandbefestigung
 Rociador ducha rectangular montaje en pared con agua cascada 500x160 mm
 Tête de douche rectangulaire attaque mur avec de l'eau de la cascade 500x160 mm

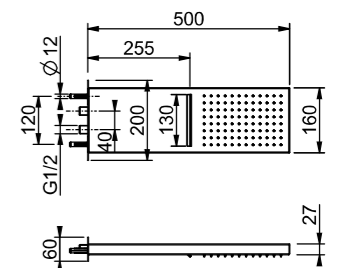

COMPLEMENTS

Soffione doccia rettangolare attacco a parete 500x240 mm

Shower head rectangular wall mount 500x240 mm
 Kopfbrause 500x240 mm - mit direkter Wandbefestigung
 Rociador ducha rectangular montaje en pared 500x240 mm
 Tête de douche rectangulaire attaque mur 500x240 mm

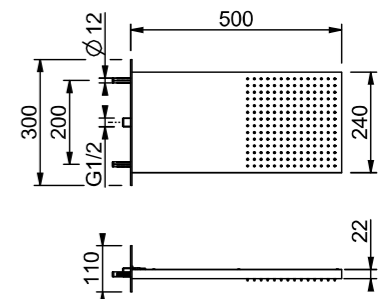

IT	DE	EN	F
SA = Satinato	SA = Satiniert	SA = Satin	SA = Satinée
LU = Lucido	LU = Glaenzend	LU = Polished	LU = Poli
PVD = Colori speciali	PVD = Sonderfarben	PVD = Special colour	PVD = Couleurs spéciales

COMPLEMENTS

Soffione doccia rettangolare attacco a parete c/cascata acqua 500x240 mm

Shower head rectangular wall mount with waterfall water 500x240 mm
 Kopfbrause mit Schwalldusche 500x240 mm - mit direkter Wandbefestigung
 Rociador ducha rectangular montaje en pared con agua cascada 500x240 mm
 Tête de douche rectangulaire attaque mur avec cascade d'eau 500x240 mm

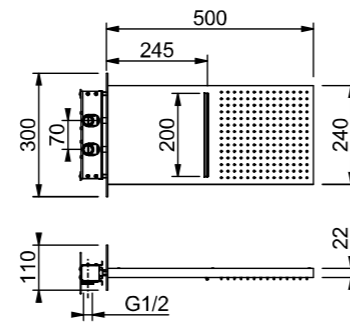

COMPLEMENTS

Soffione doccia ultrapiatto rettangolare attacco a parete 500x200 mm

Ultraflat shower head rectangular wall mount 500x200 mm
 Flache Kopfbrause 500x160x2 mm - mit direkter Wandbefestigung
 Rociador ducha ultraflat rectangular montaje pared 500x200 mm
 Tête de douche ultraplate rectangulaire attaque au mur 500x200 mm

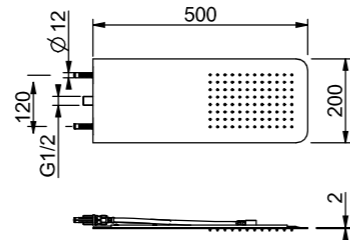

COMPLEMENTS

Soffione doccia ultrapiatto rettangolare attacco a parete c/cascata 500x200 mm

Ultraflat shower head rectangular wall mount with waterfall water 500x200 mm
 Flache Kopfbrause mit Schwalldusche 500x160x2 mm - mit direkter Wandbefestigung
 Rociador ducha ultraflat rectangular montaje pared con agua cascada 500x200 mm
 Tête de douche ultraplate rectangulaire attaque au mur avec cascade d'eau 500x200 mm

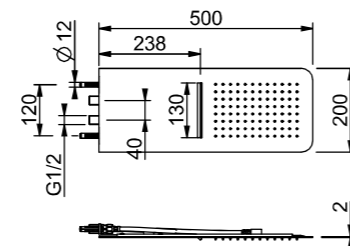

COMPLEMENTS

Colonna doccia da terra c/mix, soffione/doccetta e corpo incasso

Floor shower column with mixer, diverter, showerhead & handshower.
 Dusche, Höhe 2352 mm, Ausladung 450 mm, Einhebelmischer, Kopfbrause, Handbrause,
 Befestigungselement für Bodenmontage, Inkl. Umsteller
 Columna de ducha desde el suelo con mezclador, rociador ducha, ducha de mano y
 cuerpo empotrado
 Colonne douche du sol avec mélangeur, tête de douche, douche à main et le corps encastré

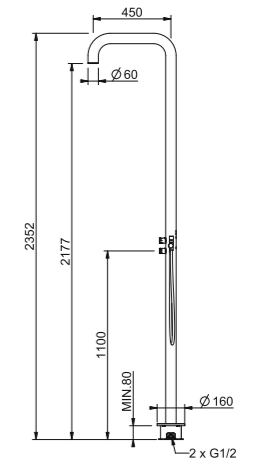

COMPLEMENTS

Colonna doccia da terra c/alimentazione esterna, deviatore, soffione e doccetta

Wall shower column with thermostatic control, diverter, showerhead & handshower.
 Dusche, Höhe 2352 mm, Ausladung 450 mm, Umsteller, Kopfbrause, Handbrause, Kaltwasser,
 Anschluss
 Columna de ducha desde el suelo con alimentación externa, desviador, rociador ducha y
 ducha de mano
 Colonne douche de sol avec alimentation extérieure, deviateur, tête de douche et douchette

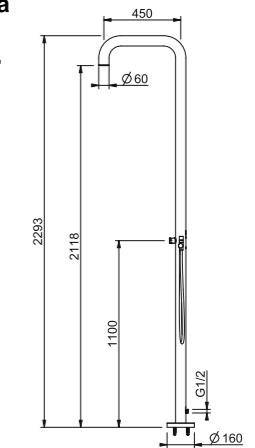

IT
 SA = Satinato
 LU = Lucido
 PVD = Colori speciali

DE
 SA = Satiniert
 LU = Glänzend
 PVD = Sonderfarben

EN
 SA = Satin
 LU = Polished
 PVD = Special colour

F
 SA = Satinée
 LU = Poli
 PVD = Couleurs spéciales

IT
 SA = Satinato
 LU = Lucido
 PVD = Colori speciali

DE
 SA = Satiniert
 LU = Glänzend
 PVD = Sonderfarben

EN
 SA = Satin
 LU = Polished
 PVD = Special colour

F
 SA = Satinée
 LU = Poli
 PVD = Couleurs spéciales