

*QUANDO L'ESSENZIALE
PRENDE FORMA*

WHEN THE ESSENTIAL
TAKES SHAPE

CUANDO EL ESENCIAL
TOMA FORMA

L3



L3

STAINLESS STEEL AISI304

MADE IN ITALY

ELEGANZA E PRECISIONE

Non c'è alcuna collocazione arbitraria.
Tutto si può combinare con tutto.
Ne consegue una progettazione
a misura d'uomo.

There is no arbitrary collocation.
Everything can be combined.
The result a project on measure.

No hay ninguna colocación arbitraria.
Todo se puede combinar con todo.
La consecuencia un proyecto a medida.



L3
Rubinetto apri/chiedi a piano, acqua calda 1/2"
Deck mounted shut-off valve, hot water.
Kaltwasser Absperrventil.
Grifo individual de repisa, agua caliente.
Robinet d'ouverture et d'arret sur plan, eau chaude.

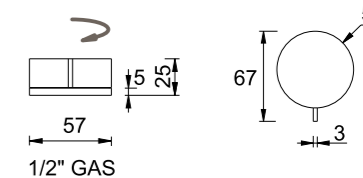

RA -rame/copper bronze **GO** -british gold **GM** -nero/gunmetal



L3
Rubinetto apri/chiedi a piano, acqua fredda 1/2"
Deck mounted shut-off valve, cold water.
Kaltwasser Absperrventil.
Grifo individual de repisa, agua fria.
Robinet d'ouverture et d'arret sur plan, eau froide.

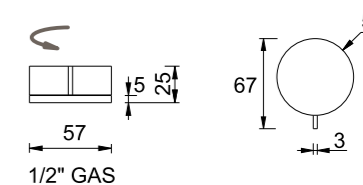

RA -rame/copper bronze **GO** -british gold **GM** -nero/gunmetal

ANNOTAZIONI:

- IT** Il simbolo freccia indica il verso di chiusura acqua.
EN The arrow symbol indicates the direction of closing water.
DE Das Pfeilsymbol zeigt die Richtung an das Wasser des Schließens.
F Le symbole de la flèche indique la direction de fermer l'eau.
ES El símbolo de la flecha indica la dirección de cerrando la agua.

IT
SA = Satinato
LU = Lucido
PVD = Colori speciali

DE
SA = Satiniert
LU = Glänzend
PVD = Sonderfarben

EN
SA = Satin
LU = Polished
PVD = Special colour

F
SA = Satinée
LU = Poli
PVD = Couleurs spéciales



L3
Rubinetto apri/chiedi a parete , acqua fredda 1/2"
 Wall mounted shut-off valve, cold water 1/2".
 Wandeinbau Absperrventil, Kaltwasser 1/2".
 Grifo individual mural, agua fria 1/2".
 Robinet d'ouverture et d'arret mural, eau froide 1/2".

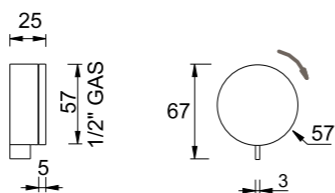

RA -rame/copper bronze GO -british gold GM -nero/gunmetal



L3
Rubinetto apri/chiedi a parete , acqua fredda 3/4"
 Wall mounted shut-off valve, cold water 3/4".
 Wandeinbau Absperrventil, Kaltwasser 3/4".
 Grifo individual mural, agua fria 3/4".
 Robinet d'ouverture et d'arret mural, eau froide 3/4".

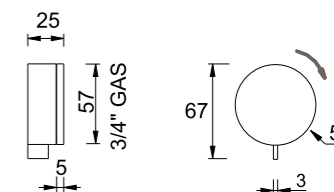

RA -rame/copper bronze GO -british gold GM -nero/gunmetal

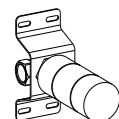

L3
Corpo ad incasso per art. MO01DX
 Concealed valve for art. MO01DX.
 Unterputzteil zu art. MO01DX.
 Mecanismo empotrado para art. MO01DX.
 Corps d'encastrement pour art. MO01DX.

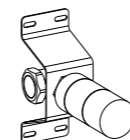
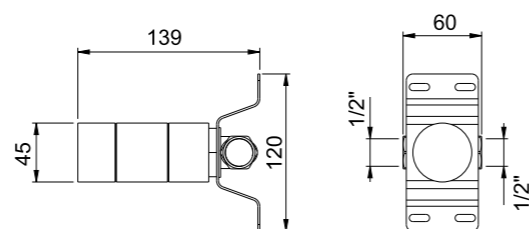

L3
Corpo ad incasso per art. MO03DX
 Concealed valve for art. MO03DX.
 Unterputzteil zu art. MO03DX.
 Mecanismo empotrado para art. MO03DX.
 Corps d'encastrement pour art. MO03DX.

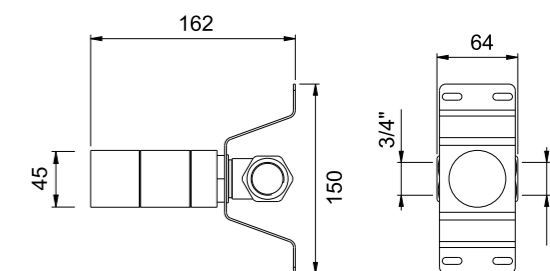

L3
Rubinetto apri/chiedi a parete , acqua calda 1/2"
 Wall mounted shut-off valve, hot water 1/2".
 Wandeinbau Absperrventil, Warmwasser 1/2".
 Grifo individual mural, agua caliente 1/2".
 Robinet d'ouverture et d'arret mural, eau chaude 1/2".

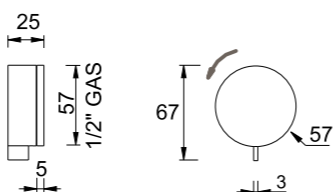

RA -rame/copper bronze GO -british gold GM -nero/gunmetal



L3
Rubinetto apri/chiedi a parete , acqua calda 3/4"
 Wall mounted shut-off valve, hot water 3/4".
 Wandeinbau Absperrventil, Warmwasser 3/4".
 Grifo individual mural, agua caliente 3/4".
 Robinet d'ouverture et d'arret mural, eau chaude 3/4".

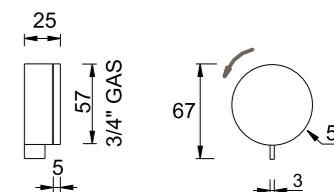

RA -rame/copper bronze GO -british gold GM -nero/gunmetal

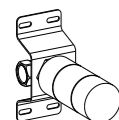

L3
Corpo ad incasso per art. MO01SX
 Concealed valve for art. MO01SX.
 Unterputzteil zu art. MO01SX.
 Mecanismo empotrado para art. MO01SX.
 Corps d'encastrement pour art. MO01SX.

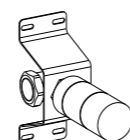
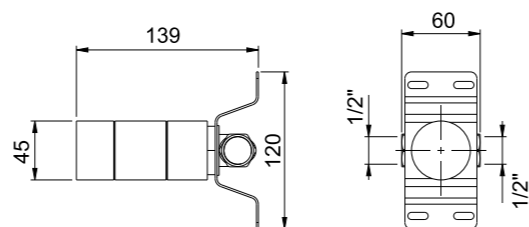

L3
Corpo ad incasso per art. MO03SX
 Concealed valve for art. MO03SX.
 Unterputzteil zu art. MO03SX.
 Mecanismo empotrado para art. MO03SX.
 Corps d'encastrement pour art. MO03SX.

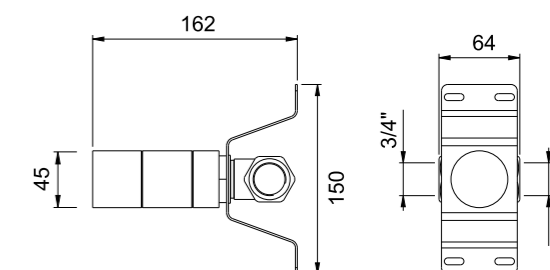

IT	DE	EN	F
SA = Satinato	SA = Satiniert	SA = Satin	SA = Satinée
LU = Lucido	LU = Glänzend	LU = Polished	LU = Poli
PVD = Colori speciali	PVD = Sonderfarben	PVD = Special colour	PVD = Couleurs spéciales

IT	DE	EN	F
SA = Satinato	SA = Satiniert	SA = Satin	SA = Satinée
LU = Lucido	LU = Glänzend	LU = Polished	LU = Poli
PVD = Colori speciali	PVD = Sonderfarben	PVD = Special colour	PVD = Couleurs spéciales



L3

Miscelatore idroprogressivo a piano
Deck mounted hydroprogressive mixer.
Hydroprogressiver Mischer.
Grifo monomando hidroprogresivo de repisa.
Mitigeur hydroprogressif sur plan.

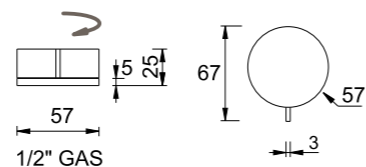

RA -rame/copper bronze GO -british gold GM -nero/gunmetal



L3

Miscelatore idroprogressivo a parete
Wall mounted hydroprogressive mixer.
Wandebau hydroprogressiver Mischer.
Grifo monomando hidroprogresivo mural.
Mitigeur hydroprogressif mural.

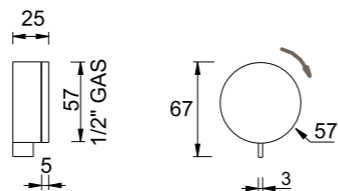

RA -rame/copper bronze GO -british gold GM -nero/gunmetal

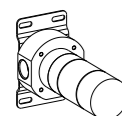

L3

Corpo ad incasso per art. MO11
Concealed valve for art. MO11.
Unterputzteil zu art. MO11.
Mecanismo empotrado para art. MO11.
Corps d'encastrement pour art. MO11.

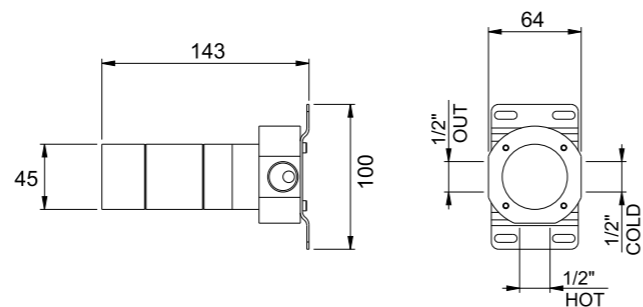

RA -rame/copper bronze GO -british gold GM -nero/gunmetal



L3

Maniglia per deviatore doccia/vasca incasso a parete «parte esterna»
Diverter shower/tub recessed wall «outside part»
Griff f. Umsteller
Desviador ducha/bañera empotrada en la pared «parte externo»
Déviateur douche/baignoire encastré mur «partie externe»

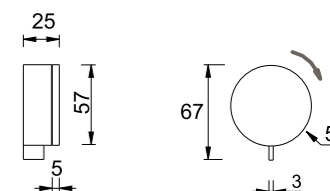

RA -rame/copper bronze GO -british gold GM -nero/gunmetal

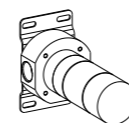

L3

Corpo ad incasso per deviatore 2 vie art. MO20
Concealed valve for 2 way diverter art. MO20 .
Unterputzteil zu art. MO20.
Mecanismo empotrado para 2 vias desviador art. MO20.
Corps d'encastrement pour déviateur 2 voies art. MO20.

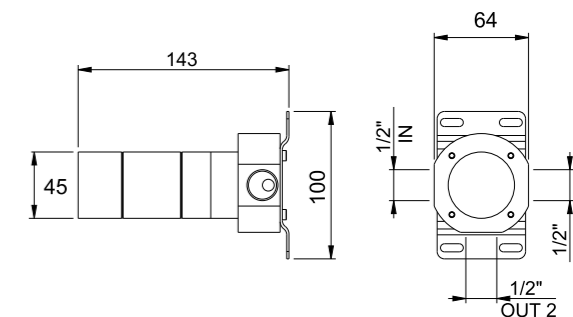

L3

Maniglia per deviatore doccia/vasca incasso a parete «parte esterna»
Diverter shower/tub recessed wall «outside part»
Griff f. Umsteller
Desviador ducha/bañera empotrada en la pared «parte externo»
Déviateur douche/baignoire encastré au mur «partie extérieure»

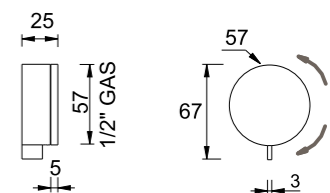

RA -rame/copper bronze GO -british gold GM -nero/gunmetal

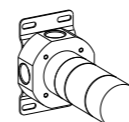

L3

Corpo ad incasso per deviatore 3 vie art. MO21
Concealed valve for 3 way diverter art. MO21 .
Unterputzteil zu art. MO21.
Mecanismo empotrado para 3 vias desviador art. MO21.
Corps d'encastrement pour déviateur 3 voies art. MO21.

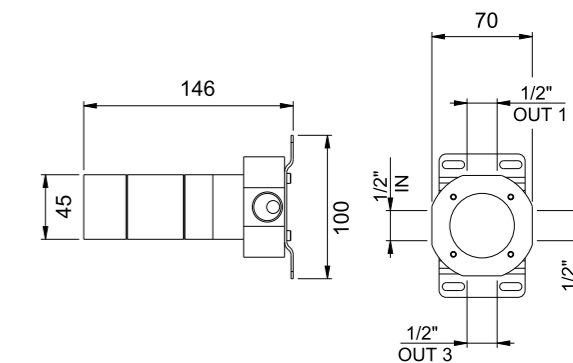

IT
SA = Satinato
LU = Lucido
PVD = Colori speciali

DE
SA = Satiniert
LU = Glänzend
PVD = Sonderfarben

EN
SA = Satin
LU = Polished
PVD = Special colour

F
SA = Satinée
LU = Poli
PVD = Couleurs spéciales

IT
SA = Satinato
LU = Lucido
PVD = Colori speciali

DE
SA = Satiniert
LU = Glänzend
PVD = Sonderfarben

EN
SA = Satin
LU = Polished
PVD = Special colour

F
SA = Satinée
LU = Poli
PVD = Couleurs spéciales

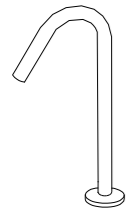

COMPLEMENTS

Bocca lavabo appoggio forma a cigno H 250 mm

Deck mounted swan-neck basin spout H 250 mm
Schwanenhalsfoermiger-Auslauf H 250 mm
Caño repisa en forma de cisne H 250 mm
Bouche lavabo soutien forme de cygne H 250 mm

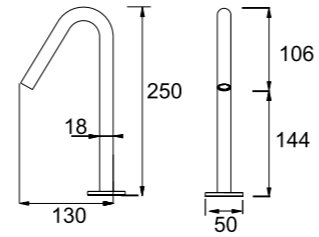

RA -rame/copper bronze GO -british gold GM -nero/gunmetal

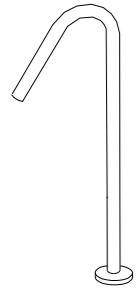

COMPLEMENTS

Bocca lavabo appoggio forma a cigno H 350 mm

Deck mounted swan-neck basin spout H 350 mm
Schwanenhalsfoermiger-Auslauf H 350 mm - Ausladung 136 mm
Caño repisa en forma de cisne H 350 mm
Bouche lavabo soutien forme de cygne H 350 mm

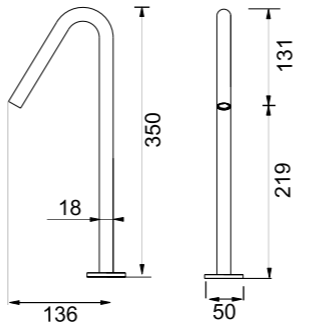

RA -rame/copper bronze GO -british gold GM -nero/gunmetal

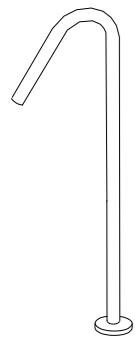

COMPLEMENTS

Bocca lavabo appoggio forma a cigno H 480 mm

Deck mounted swan-neck basin spout H 480 mm
Schwanenhalsfoermiger Auslauf H 480 mm - Ausladung 136 mm
Caño repisa en forma de cisne H 480 mm
Bouche lavabo soutien forme de cygne H 480 mm

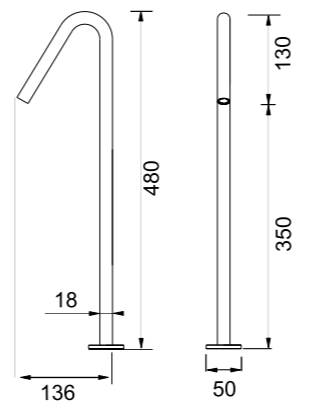

RA -rame/copper bronze GO -british gold GM -nero/gunmetal

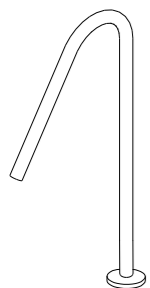

COMPLEMENTS

Bocca lavabo appoggio forma a cigno H 400 mm

Deck mounted swan-neck basin spout H 400 mm
Schwanenhalsfoermiger-Auslauf H 400 mm - Ausladung 220 mm
Caño repisa en forma de cisne H 400 mm
Bouche lavabo soutien forme de cygne H 400 mm

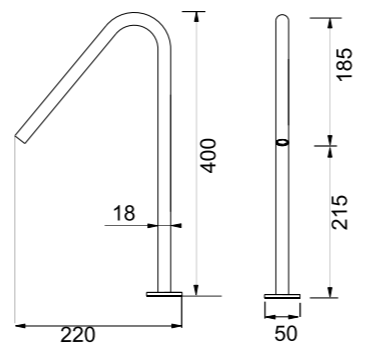

RA -rame/copper bronze GO -british gold GM -nero/gunmetal

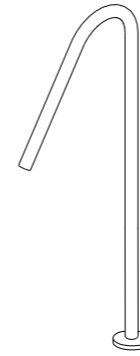

COMPLEMENTS

Bocca lavabo appoggio forma a cigno H 480 mm

Deck mounted swan-neck basin spout H 480 mm
Schwanenhalsfoermiger-Auslauf H 480 mm - Ausladung 220 mm
Caño repisa en forma de cisne H 480 mm
Bouche lavabo soutien forme de cygne H 480 mm

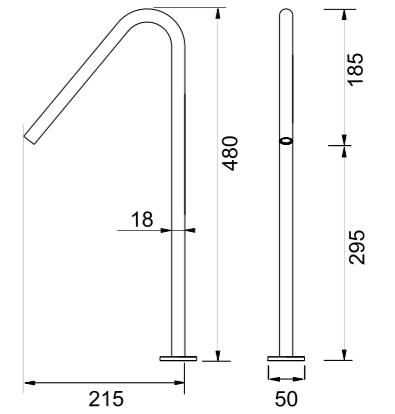

RA -rame/copper bronze GO -british gold GM -nero/gunmetal

IT	DE	EN	F
SA = Satinato	SA = Satiniert	SA = Satin	SA = Satinée
LU = Lucido	LU = Glaenzend	LU = Polished	LU = Poli
PVD = Colori speciali	PVD = Sonderfarben	PVD = Special colour	PVD = Couleurs spéciales

IT	DE	EN	F
SA = Satinato	SA = Satiniert	SA = Satin	SA = Satinée
LU = Lucido	LU = Glaenzend	LU = Polished	LU = Poli
PVD = Colori speciali	PVD = Sonderfarben	PVD = Special colour	PVD = Couleurs spéciales

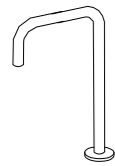

COMPLEMENTS

Bocca lavabo appoggio forma quadra H 250 mm

Deck mounted square neck basin spout H 250 mm
U-foermiger Auslauf H 250 mm
Caño repisa en forma cuadrada H 250 mm
Bouche lavabo soutien forme carrée H 250 mm

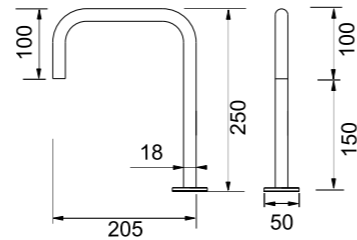

RA -rame/copper bronze GO -british gold GM -nero/gunmetal

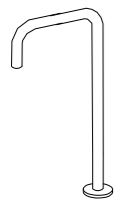

COMPLEMENTS

Bocca lavabo appoggio forma quadra H 300 mm

Deck mounted square neck basin spout H 300 mm
U-foermiger Auslauf H 300 mm - Ausladung 205 mm
Caño repisa en forma cuadrada H 300 mm
Bouche lavabo soutien forme carrée H 300 mm

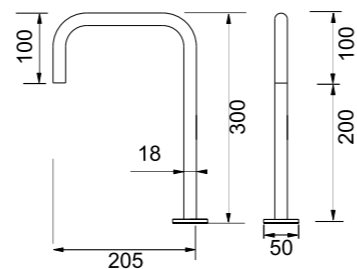

RA -rame/copper bronze GO -british gold GM -nero/gunmetal

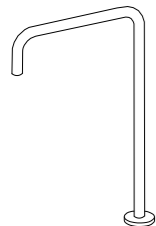

COMPLEMENTS

Bocca lavabo appoggio forma quadra H 350 mm

Deck mounted square neck basin spout H 350 mm
U-foermiger Auslauf H 350 mm - Ausladung 280 mm
Caño repisa en forma cuadrada H 350 mm
Bouche lavabo soutien forme carrée H 350 mm

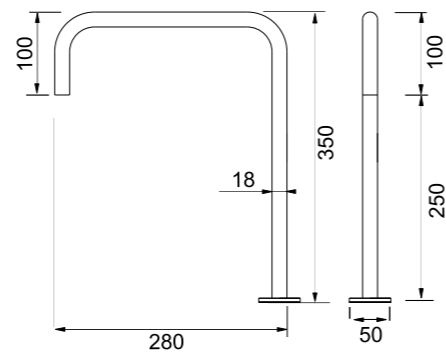

RA -rame/copper bronze GO -british gold GM -nero/gunmetal

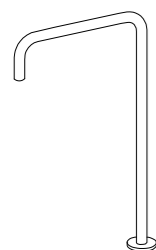

COMPLEMENTS

Bocca lavabo appoggio forma quadra H 400 mm

Deck mounted square neck basin spout H 400 mm
U-foermiger Auslauf H 400 mm - Ausladung 280 mm
Caño repisa en forma cuadrada H 400 mm
Bouche lavabo soutien forme carrée H 400 mm

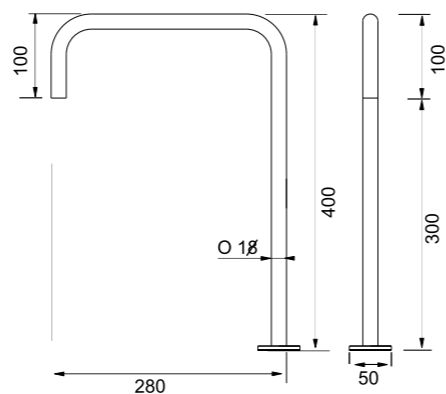

RA -rame/copper bronze GO -british gold GM -nero/gunmetal



COMPLEMENTS

Corpo incasso bocche lavabo/bidet/vasca a parete

Concealed valve basin - bidet - tub for wall mount spout.
Unterputz-Einbauteil f. Wandauslauf mit Befestigungsplatte
Cuerpo empotrado caño de lavabo - bidé - bañera a pared
Corps encastré bouches lavabo - bidet - baignoire à mur

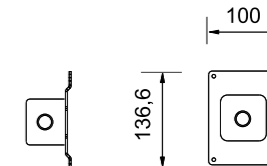

COMPLEMENTS

Bocca lavabo incasso a parete P 130 mm

Wall mount sink spout, concealed valve not included P 130 mm.
Wandauslauf - Ausladung 130 mm
Caño a pared, cuerpo empotrado no incluido P 130 mm.
Bec encastré mural pour lavabo, sans corps d'encastrement P 130 mm.

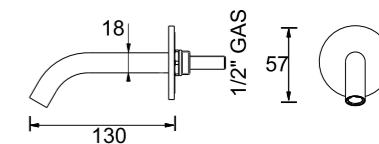

RA -rame/copper bronze GO -british gold GM -nero/gunmetal



COMPLEMENTS

Bocca lavabo incasso a parete P 160 mm

Wall mount sink spout, concealed valve not included P 160 mm.
Wandauslauf - Ausladung 160 mm
Caño a pared, cuerpo empotrado no incluido P 160 mm.
Bec encastré mural pour lavabo, sans corps d'encastrement P 160 mm.

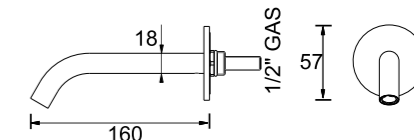

RA -rame/copper bronze GO -british gold GM -nero/gunmetal



COMPLEMENTS

Bocca lavabo incasso a parete P 200 mm

Wall mount sink spout, concealed valve not included P 200 mm.
Wandauslauf - Ausladung 200 mm
Caño a pared, cuerpo empotrado no incluido P 200 mm.
Bec encastré mural pour lavabo, sans corps d'encastrement P 200 mm.

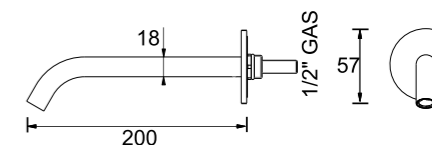

RA -rame/copper bronze GO -british gold GM -nero/gunmetal

IT
SA = Satinato
LU = Lucido
PVD = Colori speciali

DE
SA = Satiniert
LU = Glaenzend
PVD = Sonderfarben

EN
SA = Satin
LU = Polished
PVD = Special colour

F
SA = Satinée
LU = Poli
PVD = Couleurs spéciales

IT
SA = Satinato
LU = Lucido
PVD = Colori speciali

DE
SA = Satiniert
LU = Glaenzend
PVD = Sonderfarben

EN
SA = Satin
LU = Polished
PVD = Special colour

F
SA = Satinée
LU = Poli
PVD = Couleurs spéciales

COMPLEMENTS

Bocca lavabo incasso a parete P 250 mm

Wall mount sink spout, concealed valve not included P 250 mm.
Wandauslauf - Ausladung 250 mm
Caño a pared, cuerpo empotrado no incluido P 250 mm.
Bec encastré mural pour lavabo, sans corps d'encastrement P 250 mm.

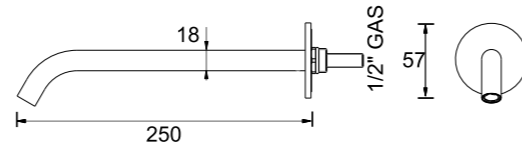

RA -rame/copper bronze GO -british gold GM -nero/gunmetal

COMPLEMENTS

Bocca a parete con erogazione orientabile P 175 mm

Wall mounted adjustable spout P 175 mm.
Wandauslauf - Ausladung 175 mm
Caño mural orientable P 175 mm.
Bec mural orientable P 175 mm.

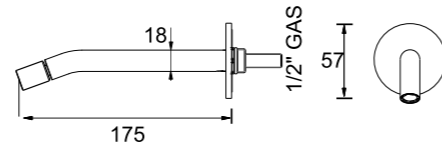

RA -rame/copper bronze GO -british gold GM -nero/gunmetal

COMPLEMENTS

Bocca erogazione orientabile da piano H 115 mm

Deck mounted adjustable spout H 115 mm.
Beweglicher Platteeinbau Auslauf H 115 mm.
Caño orientable de repisa H 115 mm.
Bec orientable sur plan H 115 mm.

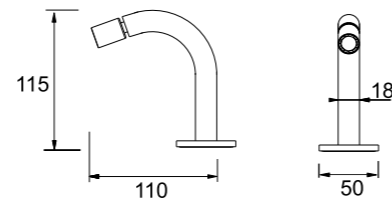

RA -rame/copper bronze GO -british gold GM -nero/gunmetal

COMPLEMENTS

Canna erogazione lavabo da terra forma a cigno H 1140 mm

Freestanding sink - tub spout H 1140 mm
Schwanenhalsfoermiger freistehender Auslauf H 1140 mm - Ausladung 220 mm
Caño a suelo para lavabo - bañera H 1140 mm
Bec d'écoulement au sol pour lavabo - baignoire H 1140 mm

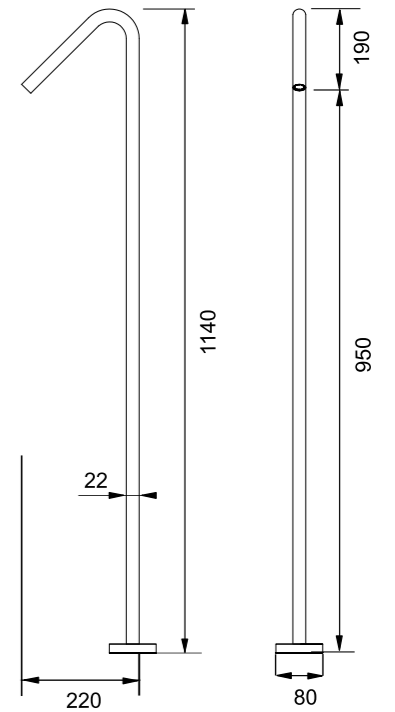

COMPLEMENTS

Canna erogazione lavabo da terra forma quadra H 1060 mm

Freestanding sink spout H 1060 mm
U-foermiger freistehender Auslauf H 1060 mm - Ausladung 315 mm
Caño a suelo para lavabo H 1060 mm
Bec d'écoulement au sol pour lavabo H 1060 mm

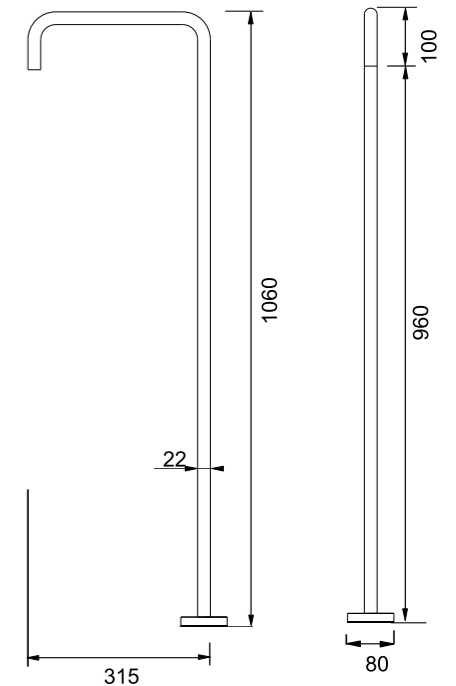

COMPLEMENTS

Corpo incasso bocche lavabo/bidet/vasca a parete

Concealed valve basin - bidet - tub for wall mount spout.
Unterputz-Einbauteil f. Wandauslauf mit Befestigungsplatte
Cuerpo empotrado caño de lavabo - bidé - bañera a pared
Corps encastré bouches lavabo - bidet - baignoire à mur

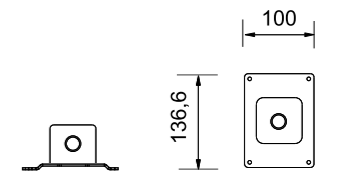

IT	DE	EN	F
SA = Satinato	SA = Satiniert	SA = Satin	SA = Satinée
LU = Lucido	LU = Glanzend	LU = Polished	LU = Poli
PVD = Colori speciali	PVD = Sonderfarben	PVD = Special colour	PVD = Couleurs spéciales

IT	DE	EN	F
SA = Satinato	SA = Satiniert	SA = Satin	SA = Satinée
LU = Lucido	LU = Glanzend	LU = Polished	LU = Poli
PVD = Colori speciali	PVD = Sonderfarben	PVD = Special colour	PVD = Couleurs spéciales

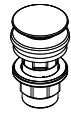

COMPLEMENTS

Piletta chiusura a pressione in ABS con rivestimento coperchio in acciaio inox

Drain pipe fitting with pressure plug in ABS finished in stainless steel.

Push-Up Ablaufgarnitur aus ABS (Edelstahloptik oder Hockglanzchrom-Optik) f. Waschbecken und Bidet

Válvula de desague a presión klik-clak en ABS, acabado en cromo brillo o acero satinado

Raccord complet avec vidage à pression klik-clak en ABS chromé brillant ou acier satiné

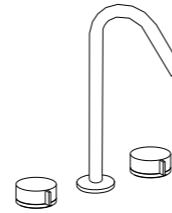
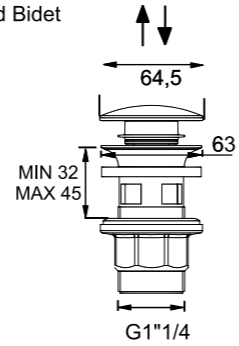

COMPLEMENTS

Piletta chiusura a pressione in ABS con rivestimento coperchio in acciaio inox

Drain pipe fitting with pressure plug in ABS finished in stainless steel.

Push-Up Ablaufgarnitur aus ABS (Edelstahloptik oder Hockglanzchrom-Optik) f. Waschbecken und Bidet

Válvula de desague a presión klik-clak en ABS, acabado en cromo brillo o acero satinado

Raccord complet avec vidage à pression klik-clak en ABS chromé brillant ou acier satiné

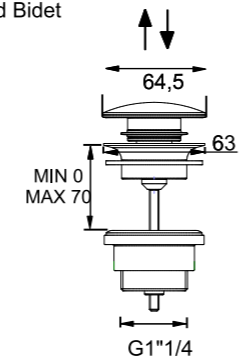

COMPLEMENTS

Piletta chiusura a pressione totalmente in acciaio inox

Drain pipe fitting with pressure plug in stainless steel.

Ablaufventil mit Klickverschluss für Waschbecken und Bidet, Stöpsel und Körper aus Edelstahl AISI 316.

Válvula de desague a presión klik-clak en acero.

Raccord complet avec vidage à pression klik-clak en acier.

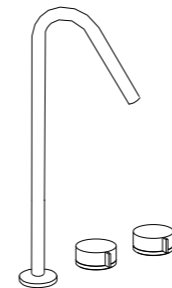
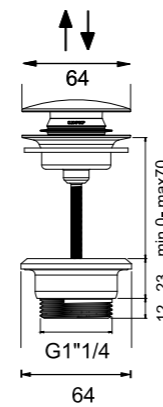

RA -rame/copper bronze GO -british gold GM -nero/gunmetal

L3

Gruppo 3 fori da piano per lavabo con erogazione e rubinetti acqua calda e fredda

Three-hole sink mixer complete with spout and command handles for hot and cold water.

3-Bohrung-Aufsatzbatterie für Becken mit Auslauf und Zweigriffmischer.

Bateria de superficie 3 taladros para lavabo con caño y mando para agua fría y caliente.

Batterie 3 trous pour lavabo avec bec d'écoulement et commandes eau chaude/eau froide.

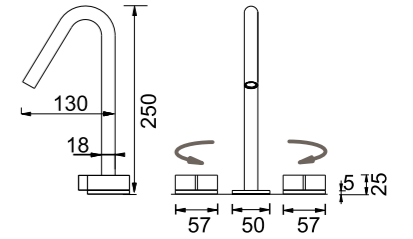

RA -rame/copper bronze GO -british gold GM -nero/gunmetal

L3

Gruppo 3 fori da piano per lavabo con erogazione e rubinetti acqua calda e fredda

Three-hole sink mixer complete with spout and command handles for hot and cold water.

3-Bohrung-Aufsatzbatterie für Becken mit Auslauf und Zweigriffmischer.

Bateria de superficie 3 taladros para lavabo con caño y mando para agua fría y caliente.

Batterie 3 trous pour lavabo avec bec d'écoulement et commandes eau chaude/eau froide.

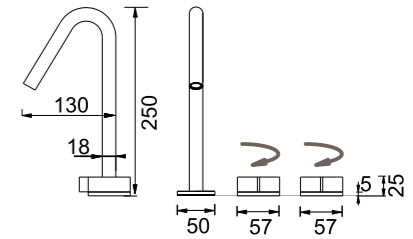

RA -rame/copper bronze GO -british gold GM -nero/gunmetal

L3

Gruppo 3 fori da piano per lavabo con erogazione e rubinetti acqua calda e fredda

Three-hole sink mixer complete with spout and command handles for hot and cold water.

3-Bohrung-Aufsatzbatterie für Becken mit Auslauf und Zweigriffmischer.

Bateria de superficie 3 taladros para lavabo con caño y mando para agua fría y caliente.

Batterie 3 trous pour lavabo avec bec et commandes eau chaude/eau froide.

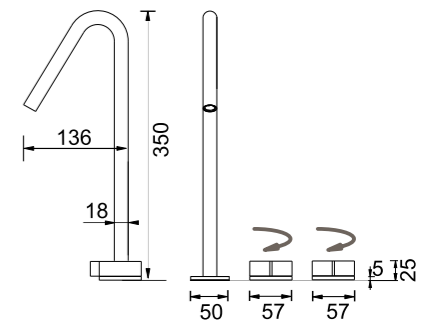

RA -rame/copper bronze GO -british gold GM -nero/gunmetal

L3

Gruppo 3 fori da piano per lavabo con erogazione e rubinetti acqua calda e fredda

Three-hole sink mixer complete with spout and command handles for hot and cold water.

3-Bohrung-Aufsatzbatterie für Becken mit Auslauf und Zweigriffmischer.

Bateria de superficie 3 taladros para lavabo con caño y mando para agua fría y caliente.

Batterie 3 trous pour lavabo avec bec et commandes eau chaude/eau froide.

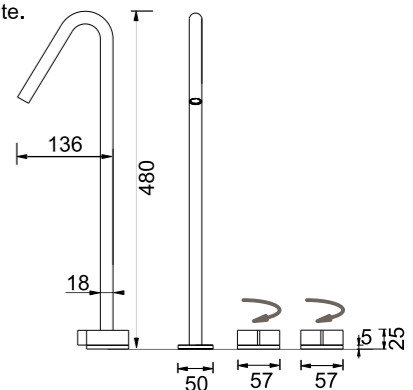

RA -rame/copper bronze GO -british gold GM -nero/gunmetal

IT
SA = Satinato
LU = Lucido
PVD = Colori speciali

DE
SA = Satiniert
LU = Glänzend
PVD = Sonderfarben

EN
SA = Satin
LU = Polished
PVD = Special colour

F
SA = Satinée
LU = Poli
PVD = Couleurs spéciales

IT
SA = Satinato
LU = Lucido
PVD = Colori speciali

DE
SA = Satiniert
LU = Glänzend
PVD = Sonderfarben

EN
SA = Satin
LU = Polished
PVD = Special colour

F
SA = Satinée
LU = Poli
PVD = Couleurs spéciales

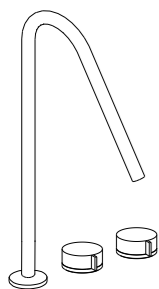

L3

Gruppo 3 fori da piano per lavabo con erogazione e rubinetti acqua calda e fredda

Three-hole sink mixer complete with spout and command handles for hot and cold water.
3-Bohrung-Aufsatzbatterie für Becken mit Auslauf und Zweigriffmischer.
Bateria de superficie 3 taladros para lavabo con caño y mando para agua fría y caliente.
Batterie 3 trous pour lavabo avec bec et commandes eau chaude/eau froide.

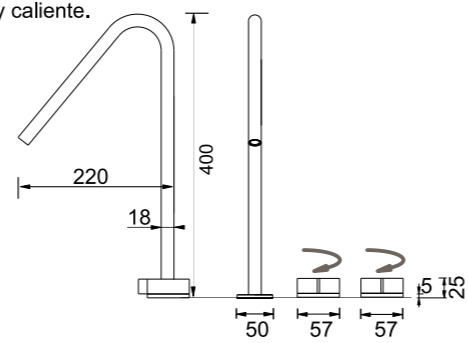

RA -rame/copper bronze GO -british gold GM -nero/gunmetal

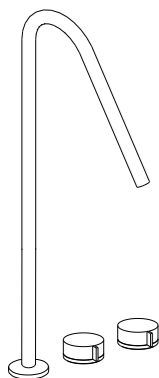

L3

Gruppo 3 fori da piano per lavabo con erogazione e rubinetti acqua calda e fredda

Three-hole sink mixer complete with spout and command handles for hot and cold water.
3-Bohrung-Aufsatzbatterie für Becken mit Auslauf und Zweigriffmischer.
Bateria de superficie 3 taladros para lavabo con caño y mando para agua fría y caliente.
Batterie 3 trous pour lavabo avec bec et commandes eau chaude/eau froide.

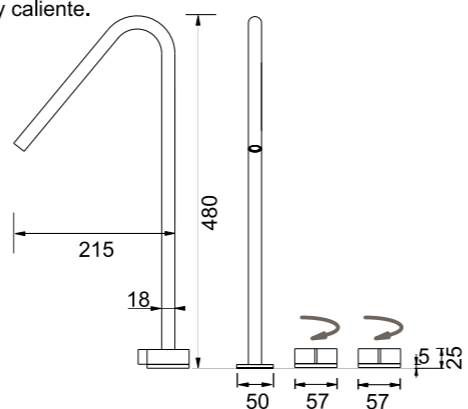

RA -rame/copper bronze GO -british gold GM -nero/gunmetal

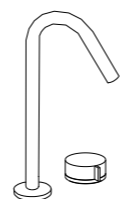

L3

Miscelatore idroprogressivo 2 fori con bocca erogazione

Two-hole hydroprogressive mixer with spout.
Hydroprogressiver Zweilocharmatur Mischer mit Auslauf.
Mezclador hidroprogressivo con 2 orificios y caño.
Mitigeur hydroprogressif 2 trous avec bec.

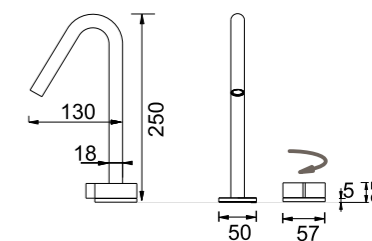

RA -rame/copper bronze GO -british gold GM -nero/gunmetal

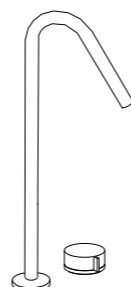

L3

Miscelatore idroprogressivo 2 fori con bocca erogazione

Two-hole hydroprogressive mixer with spout.
Hydroprogressiver Zweilocharmatur Mischer mit Auslauf.
Mezclador hidroprogressivo con 2 orificios y caño.
Mitigeur hydroprogressif 2 trous avec bec.

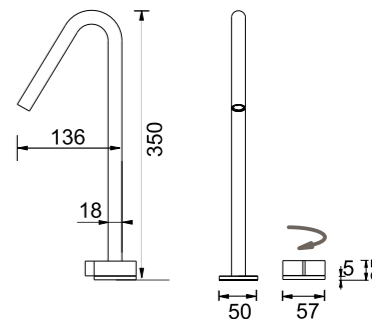

RA -rame/copper bronze GO -british gold GM -nero/gunmetal

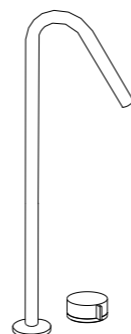

L3

Miscelatore idroprogressivo 2 fori con bocca erogazione

Two-hole hydroprogressive mixer with spout.
Hydroprogressiver Zweilocharmatur Mischer mit Auslauf.
Mezclador hidroprogressivo con 2 orificios y caño.
Mitigeur hydroprogressif 2 trous avec bec.

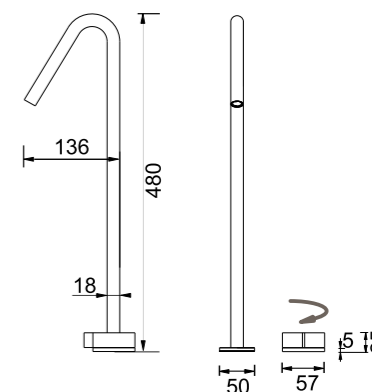

RA -rame/copper bronze GO -british gold GM -nero/gunmetal



L3

Miscelatore idroprogressivo 2 fori con bocca erogazione

Two-hole hydroprogressive mixer with spout.
Hydroprogressiver Zweilocharmatur Mischer mit Auslauf.
Mezclador hidroprogressivo con 2 orificios y caño.
Mitigeur hydroprogressif 2 trous avec bec.

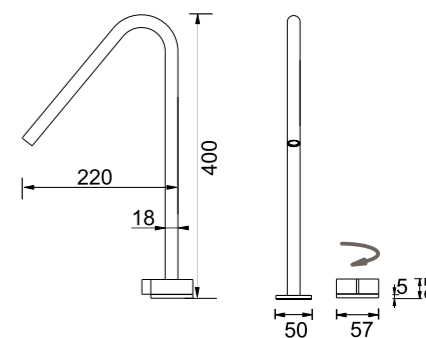

RA -rame/copper bronze GO -british gold GM -nero/gunmetal

IT
SA = Satinato
LU = Lucido
PVD = Colori speciali

DE
SA = Satiniert
LU = Glänzend
PVD = Sonderfarben

EN
SA = Satin
LU = Polished
PVD = Special colour

F
SA = Satinée
LU = Poli
PVD = Couleurs spéciales

IT
SA = Satinato
LU = Lucido
PVD = Colori speciali

DE
SA = Satiniert
LU = Glänzend
PVD = Sonderfarben

EN
SA = Satin
LU = Polished
PVD = Special colour

F
SA = Satinée
LU = Poli
PVD = Couleurs spéciales

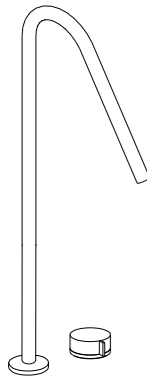

L3

Miscelatore idroprogressivo 2 fori con bocca erogazione

Two-hole hydroprogressive mixer with spout.
Hydroprogressiver Zweilocharmatur Mischer mit Auslauf.
Mezclador hidroprogresivo con 2 orificios y caño.
Mitigeur hydroprogressif 2 trous avec bec.

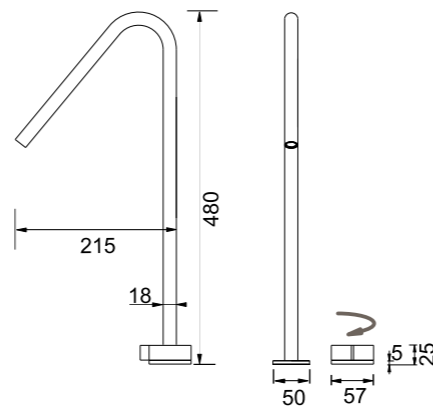

RA -rame/copper bronze **GO** -british gold **GM** -nero/gunmetal

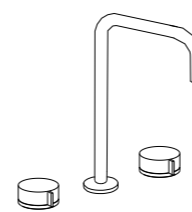

L3

Gruppo 3 fori da piano per lavabo con erogazione e rubinetti acqua calda e fredda

Three-hole sink mixer complete with spout and command handles for hot and cold water.
3-Bohrung-Aufsatzbatterie für Becken mit Auslauf und Zweigriffmischer.
Bateria de superficie 3 taladros para lavabo con caño y mando para agua fría y caliente.
Batterie 3 trous pour lavabo avec bec d'écoulement et commandes eau chaude/eau froide.

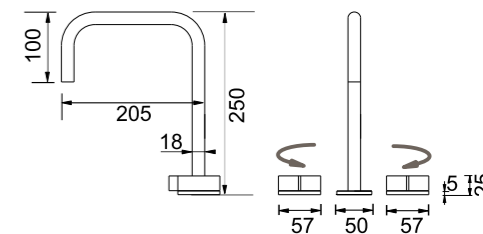

RA -rame/copper bronze **GO** -british gold **GM** -nero/gunmetal

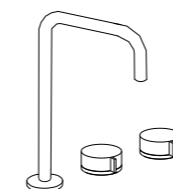

L3

Gruppo 3 fori da piano per lavabo con erogazione e rubinetti acqua calda e fredda

Three-hole sink mixer complete with spout and command handles for hot and cold water.
3-Bohrung-Aufsatzbatterie für Becken mit Auslauf und Zweigriffmischer.
Bateria de superficie 3 taladros para lavabo con caño y mando para agua fría y caliente.
Batterie 3 trous pour lavabo avec bec d'écoulement et commandes eau chaude/eau froide.

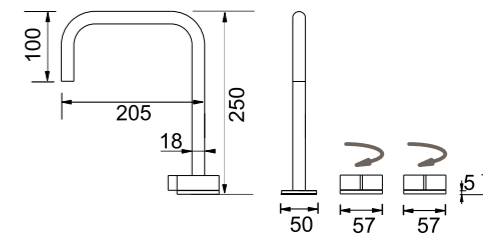

RA -rame/copper bronze **GO** -british gold **GM** -nero/gunmetal

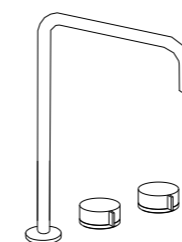

L3

Gruppo 3 fori da piano per lavabo con erogazione e rubinetti acqua calda e fredda

Three-hole sink mixer complete with spout and command handles for hot and cold water.
3-Bohrung-Aufsatzbatterie für Becken mit Auslauf und Zweigriffmischer.
Bateria de superficie 3 taladros para lavabo con caño y mando para agua fría y caliente.
Batterie 3 trous pour lavabo avec bec d'écoulement et commandes eau chaude/eau froide.

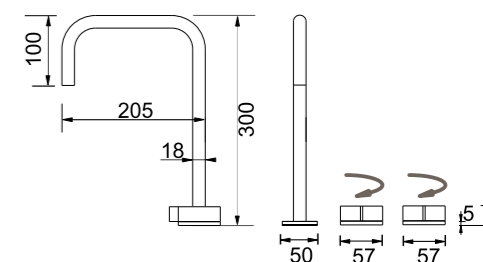

RA -rame/copper bronze **GO** -british gold **GM** -nero/gunmetal

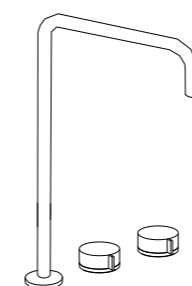

L3

Gruppo 3 fori da piano per lavabo con erogazione e rubinetti acqua calda e fredda

Three-hole sink mixer complete with spout and command handles for hot and cold water.
3-Bohrung-Aufsatzbatterie für Becken mit Auslauf und Zweigriffmischer.
Bateria de superficie para lavabo con caño y mando para agua fría y caliente.
Batterie pour lavabo avec bec et commandes eau chaude/eau froide.

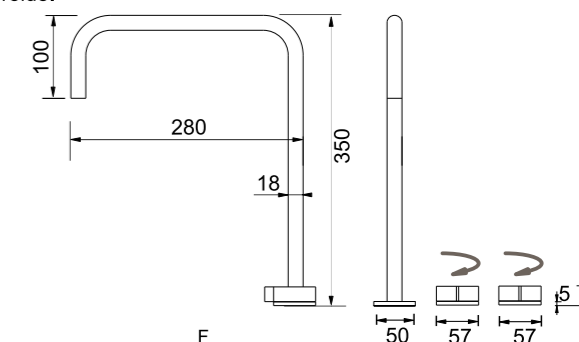

RA -rame/copper bronze **GO** -british gold **GM** -nero/gunmetal

IT
SA = Satinato
LU = Lucido
PVD = Colori speciali

DE
SA = Satiniert
LU = Glänzend
PVD = Sonderfarben

EN
SA = Satin
LU = Polished
PVD = Special colour

F
SA = Satinée
LU = Poli
PVD = Couleurs spéciales

IT
SA = Satinato
LU = Lucido
PVD = Colori speciali

DE
SA = Satiniert
LU = Glänzend
PVD = Sonderfarben

EN
SA = Satin
LU = Polished
PVD = Special colour

F
SA = Satinée
LU = Poli
PVD = Couleurs spéciales

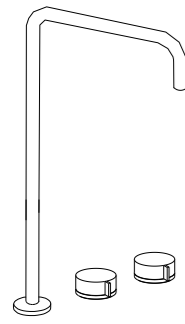

L3

Gruppo 3 fori da piano per lavabo con erogazione e rubinetti acqua calda e fredda

Three-hole sink mixer complete with spout and command handles for hot and cold water.
 3-Bohrung-Aufsatzbatterie für Becken mit Auslauf und Zweigriffmischer.
 Bateria de superficie 3 taladros para lavabo con caño y mando para agua fría y caliente.
 Batterie 3 trous pour lavabo avec bec et commandes eau chaude/eau froide.

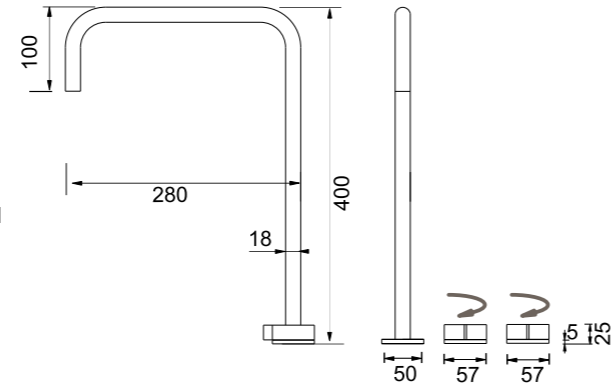

RA -rame/copper bronze GO -british gold GM -nero/gunmetal

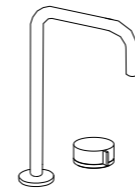

L3

Miscelatore idroprogressivo 2 fori con bocca erogazione

Two-hole hydroprogressive mixer with spout.
 Hydroprogressiver Zweilocharmatur Mischer mit Auslauf.
 Grifo hidroprogresivo con 2 orificios y caño.
 Mitigeur hydroprogressif 2 trous avec bec.

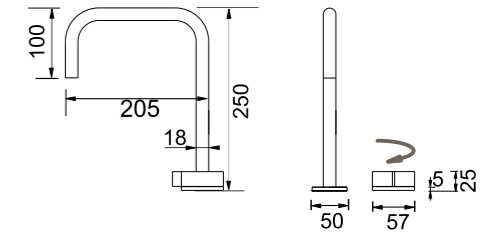

RA -rame/copper bronze GO -british gold GM -nero/gunmetal

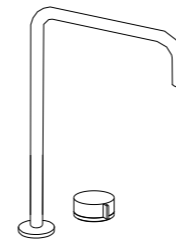

L3

Miscelatore idroprogressivo 2 fori con bocca erogazione

Two-hole hydroprogressive mixer with spout.
 Hydroprogressiver Zweilocharmatur Mischer mit Auslauf.
 Grifo hidroprogresivo con 2 orificios y caño.
 Mitigeur hydroprogressif 2 trous avec bec.

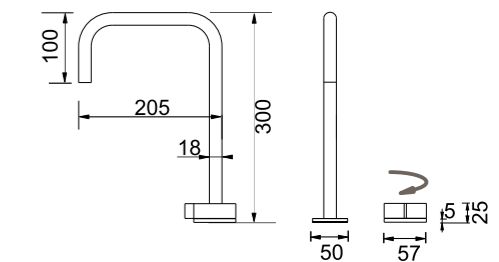

RA -rame/copper bronze GO -british gold GM -nero/gunmetal

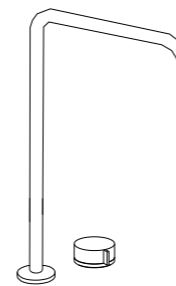

L3

Miscelatore idroprogressivo 2 fori con bocca erogazione

Two-hole hydroprogressive mixer with spout.
 Hydroprogressiver Zweilocharmatur Mischer mit Auslauf.
 Grifo hidroprogresivo con 2 orificios y caño.
 Mitigeur hydroprogressif 2 trous avec bec.

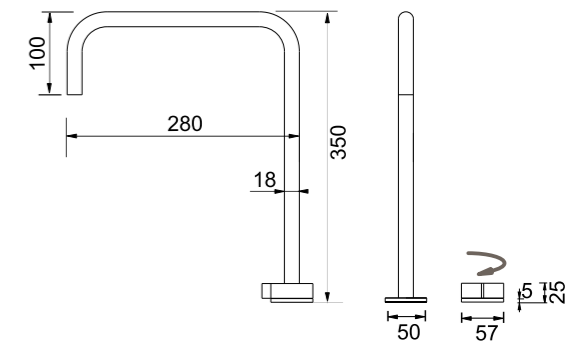

RA -rame/copper bronze GO -british gold GM -nero/gunmetal

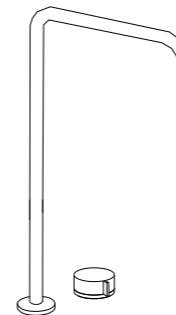

L3

Miscelatore idroprogressivo 2 fori con bocca erogazione

Two-hole hydroprogressive mixer with spout.
 Hydroprogressiver Zweilocharmatur Mischer mit Auslauf.
 Grifo hidroprogresivo con 2 orificios y caño.
 Mitigeur hydroprogressif 2 trous avec bec.

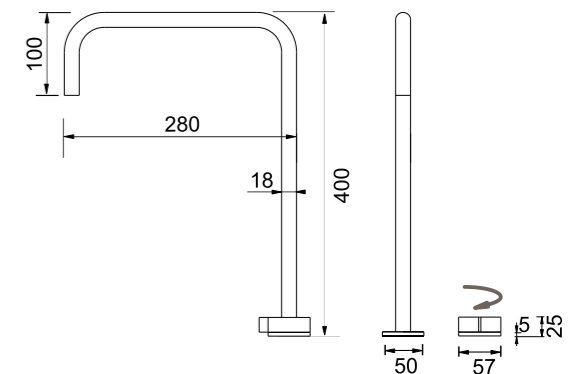

RA -rame/copper bronze GO -british gold GM -nero/gunmetal

IT	DE	EN	F
SA = Satinato	SA = Satiniert	SA = Satin	SA = Satinée
LU = Lucido	LU = Glänzend	LU = Polished	LU = Poli
PVD = Colori speciali	PVD = Sonderfarben	PVD = Special colour	PVD = Couleurs spéciales

IT	DE	EN	F
SA = Satinato	SA = Satiniert	SA = Satin	SA = Satinée
LU = Lucido	LU = Glänzend	LU = Polished	LU = Poli
PVD = Colori speciali	PVD = Sonderfarben	PVD = Special colour	PVD = Couleurs spéciales

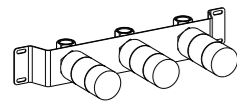

L3

Corpo ad incasso per art. MO300/13-16-20-25

Concealed valve for art. MO300/13-16-20-25.
 Unterputzteil zu art. MO300/13-16-20-25.
 Mecanismo empotrado para art. MO300/13-16-20-25.
 Corps d'encastrement pour art. MO300/13-16-20-25.

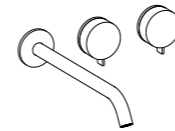
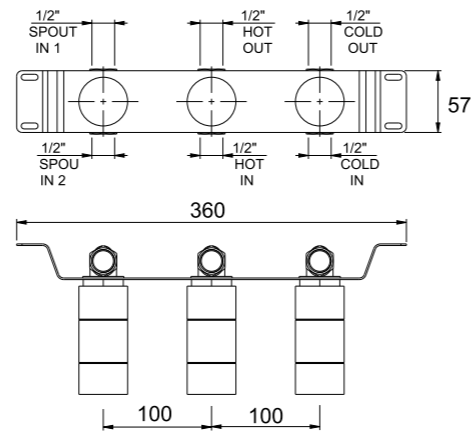

L3

Gruppo 2 rubinetti apri/chiodi a parete con bocca di erogazione 250 mm

Wall mounted set of 2 individual taps with spout 250 mm.
 Zweigriff Wandarmatur mit Auslauf 250 mm.
 Grupo griferia mural con dos llaves individuales y caño 250 mm.
 Mélangeur mural avec bec 250 mm.

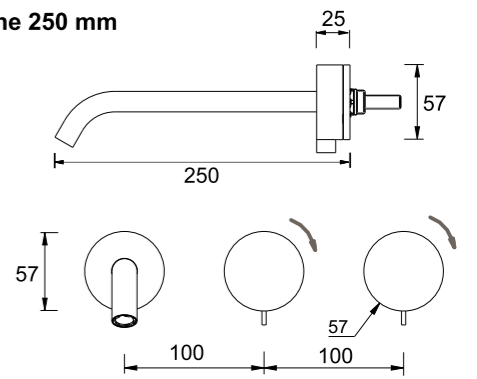

RA -rame/copper bronze **GO** -british gold **GM** -nero/gunmetal

L3

Gruppo 2 rubinetti apri/chiodi a parete con bocca di erogazione 130 mm

Wall mounted set of 2 individual taps with spout 130 mm.
 Zweigriff Wandarmatur mit Auslauf 130 mm.
 Grupo griferia mural con dos llaves individuales y caño 130 mm.
 Mélangeur mural avec bec 130 mm.

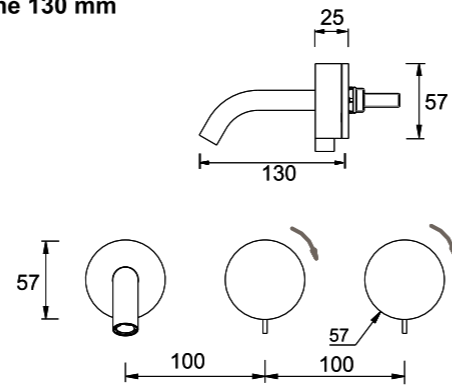

RA -rame/copper bronze **GO** -british gold **GM** -nero/gunmetal

L3

Gruppo 2 rubinetti apri/chiodi a parete con bocca di erogazione 160 mm

Wall mounted set of 2 individual taps with spout 160 mm.
 Zweigriff Wandarmatur mit Auslauf 160 mm.
 Grupo griferia mural con dos llaves individuales y caño 160 mm.
 Mélangeur mural avec bec 160 mm.

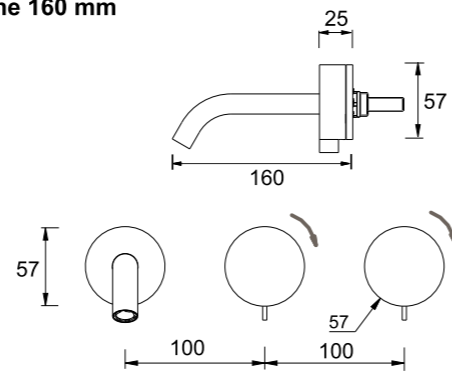
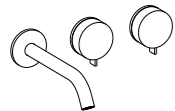

RA -rame/copper bronze **GO** -british gold **GM** -nero/gunmetal

L3

Gruppo 2 rubinetti apri/chiodi a parete con bocca di erogazione 200 mm

Wall mounted set of 2 individual taps with spout 200 mm.
 Zweigriff Wandarmatur mit Auslauf 200 mm.
 Grupo griferia mural con dos llaves individuales y caño 200 mm.
 Mélangeur mural avec bec 200 mm.

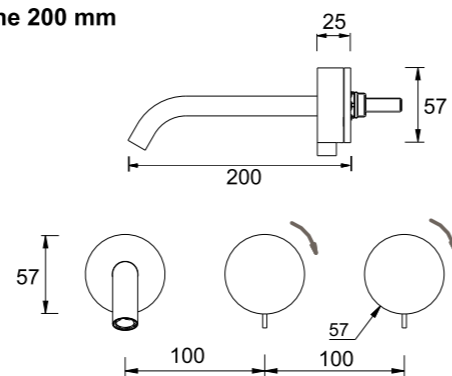
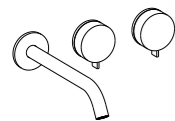

RA -rame/copper bronze **GO** -british gold **GM** -nero/gunmetal

IT	DE	EN	F
SA = Satinato	SA = Satiniert	SA = Satin	SA = Satinée
LU = Lucido	LU = Glänzend	LU = Polished	LU = Poli
PVD = Colori speciali	PVD = Sonderfarben	PVD = Special colour	PVD = Couleurs spéciales

IT	DE	EN	F
SA = Satinato	SA = Satiniert	SA = Satin	SA = Satinée
LU = Lucido	LU = Glänzend	LU = Polished	LU = Poli
PVD = Colori speciali	PVD = Sonderfarben	PVD = Special colour	PVD = Couleurs spéciales

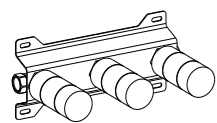

L3

Corpo ad incasso per art. MO310/13-16-20-25

Concealed valve for art. MO310/13-16-20-25.
Unterputzteil zu art. MO310/13-16-20-25.
Mecanismo empotrado para art. MO310/13-16-20-25.
Corps d'encastrement pour art. MO310/13-16-20-25.

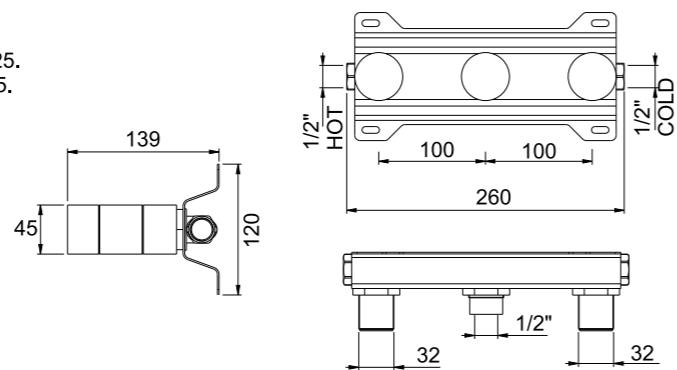

L3

Gruppo 2 rubinetti apri/chiodi a parete con bocca di erogazione 250 mm

Wall mounted set of 2 individual taps with spout 250 mm.
Zweigriff Wandarmatur mit Auslauf 250 mm.
Grupo griferia mural con dos llaves individuales y caño 250 mm.
Mélangeur mural avec bec 250 mm.

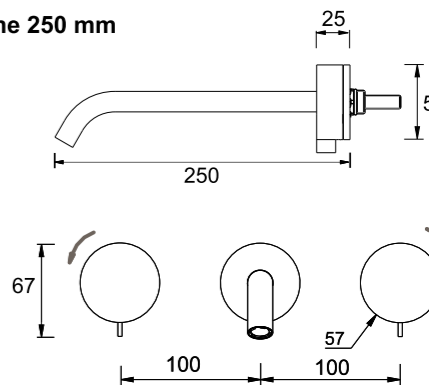
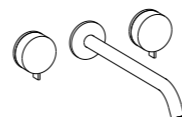

RA -rame/copper bronze **GO** -british gold **GM** -nero/gunmetal

L3

Gruppo 2 rubinetti apri/chiodi a parete con bocca di erogazione 130 mm

Wall mounted set of 2 individual taps with spout 130 mm.
Zweigriff Wandarmatur mit Auslauf 130 mm.
Grupo griferia mural con dos llaves individuales y caño 130 mm.
Mélangeur mural avec bec 130 mm.

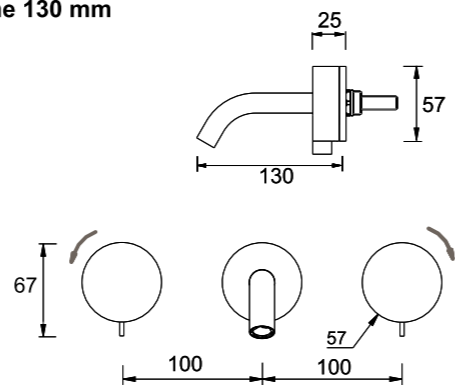

RA -rame/copper bronze **GO** -british gold **GM** -nero/gunmetal

L3

Gruppo 2 rubinetti apri/chiodi a parete con bocca di erogazione 160 mm

Wall mounted set of 2 individual taps with spout 160 mm.
Zweigriff Wandarmatur mit Auslauf 160 mm.
Grupo griferia mural con dos llaves individuales y caño 160 mm.
Mélangeur mural avec bec 160 mm.

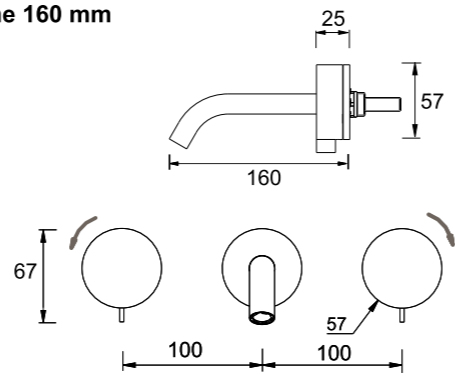
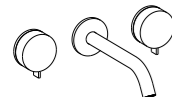

RA -rame/copper bronze **GO** -british gold **GM** -nero/gunmetal

L3

Gruppo 2 rubinetti apri/chiodi a parete con bocca di erogazione 200 mm

Wall mounted set of 2 individual taps with spout 200 mm.
Zweigriff Wandarmatur mit Auslauf 200 mm.
Grupo griferia mural con dos llaves individuales y caño 200 mm.
Mélangeur mural avec bec 200 mm.

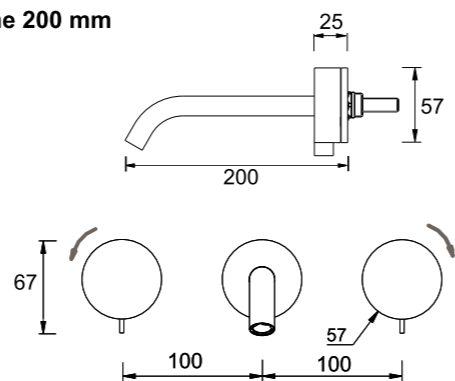
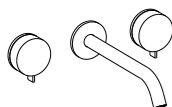

RA -rame/copper bronze **GO** -british gold **GM** -nero/gunmetal

IT	DE	EN	F
SA = Satinato	SA = Satiniert	SA = Satin	SA = Satinée
LU = Lucido	LU = Glanzend	LU = Polished	LU = Poli
PVD = Colori speciali	PVD = Sonderfarben	PVD = Special colour	PVD = Couleurs spéciales

IT	DE	EN	F
SA = Satinato	SA = Satiniert	SA = Satin	SA = Satinée
LU = Lucido	LU = Glanzend	LU = Polished	LU = Poli
PVD = Colori speciali	PVD = Sonderfarben	PVD = Special colour	PVD = Couleurs spéciales

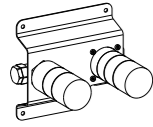

L3

Corpo ad incasso per art. MO320/13-16-20-25

Concealed valve for art. MO320/13-16-20-25.
 Unterputzteil zu art. MO320/13-16-20-25.
 Mecanismo empotrado para art. MO320/13-16-20-25.
 Corps d'encastrement pour art. MO320/13-16-20-25.

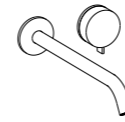
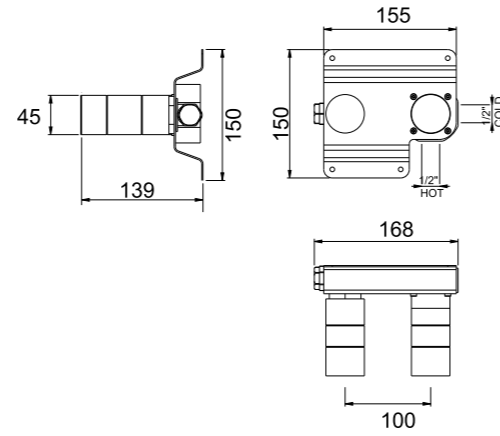

L3

Miscelatore idroprogressivo a parete con bocca di erogazione 250 mm

Wall mounted hydroprogressive mixer with spout 250 mm.
 Wandeinbau hydroprogressiver Mischer mit Auslauf 250 mm.
 Grifo hidroprogresivo mural con caño 250 mm.
 Mitigeur hydroprogressif mural avec bec 250 mm.

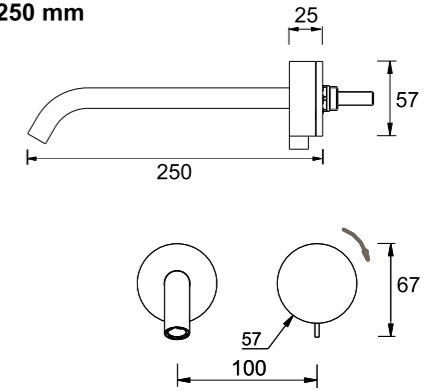

RA -rame/copper bronze **GO** -british gold **GM** -nero/gunmetal



L3

Miscelatore idroprogressivo a parete con bocca di erogazione 130 mm

Wall mounted hydroprogressive mixer with spout 130 mm.
 Wandeinbau hydroprogressiver Mischer mit Auslauf 130 mm.
 Grifo hidroprogresivo mural con caño 130 mm.
 Mitigeur hydroprogressif mural avec bec 130 mm.

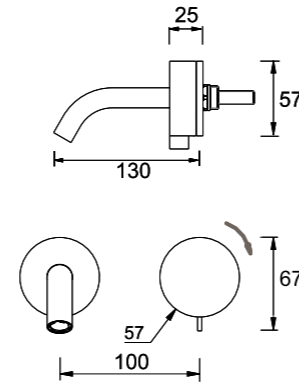

RA -rame/copper bronze **GO** -british gold **GM** -nero/gunmetal



L3

Miscelatore idroprogressivo a parete con bocca di erogazione 160 mm

Wall mounted hydroprogressive mixer with spout 160 mm.
 Wandeinbau hydroprogressiver Mischer mit Auslauf 160 mm.
 Grifo hidroprogresivo mural con caño 160 mm.
 Mitigeur hydroprogressif mural avec bec 160 mm.

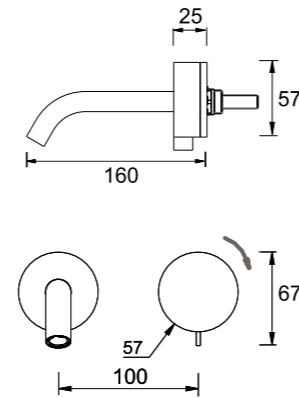

RA -rame/copper bronze **GO** -british gold **GM** -nero/gunmetal

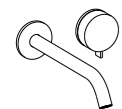

L3

Miscelatore idroprogressivo a parete con bocca di erogazione 200 mm

Wall mounted hydroprogressive mixer with spout 200 mm.
 Wandeinbau hydroprogressiver Mischer mit Auslauf 200 mm.
 Grifo hidroprogresivo mural con caño 200 mm.
 Mitigeur hydroprogressif mural avec bec 200 mm.

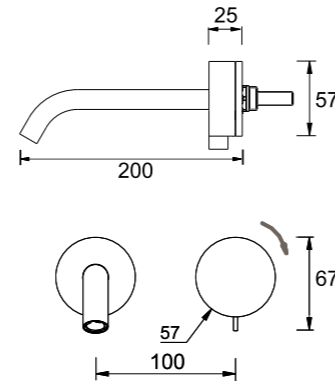

RA -rame/copper bronze **GO** -british gold **GM** -nero/gunmetal

IT	DE	EN	F
SA = Satinato	SA = Satiniert	SA = Satin	SA = Satinée
LU = Lucido	LU = Glaenzend	LU = Polished	LU = Poli
PVD = Colori speciali	PVD = Sonderfarben	PVD = Special colour	PVD = Couleurs spéciales

IT	DE	EN	F
SA = Satinato	SA = Satiniert	SA = Satin	SA = Satinée
LU = Lucido	LU = Glaenzend	LU = Polished	LU = Poli
PVD = Colori speciali	PVD = Sonderfarben	PVD = Special colour	PVD = Couleurs spéciales

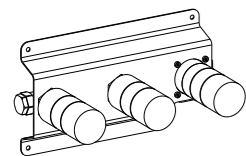

L3

Corpo ad incasso per art. MO330/13-16-20-25

Concealed valve for art. MO330/13-16-20-25.
 Unterputzteil zu art. MO330/13-16-20-25.
 Mecanismo empotrado para art. MO330/13-16-20-25.
 Corps d'encastrement pour art. MO330/13-16-20-25.

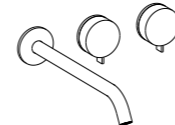
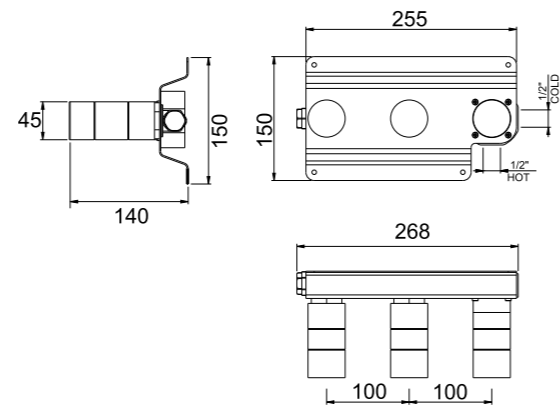

L3

Miscelatore idroprogressivo con regolatore di portata a parete e bocca di erogazione 250 mm

Wall mounted hydroprogressive mixer with flow regulator and spout 250 mm.
 Wandeinbau hydroprogressiver Mischer mit Durchflussregler mit Auslauf 250 mm.
 Grifo hidroprogresivo mural con regulador de flujo e caño 250 mm.
 Mitigeur hydroprogressif mural avec régulateur de flux e bec 250 mm.

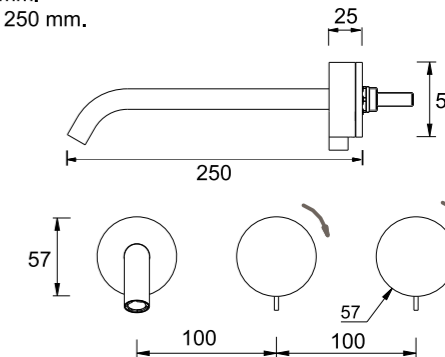

RA -rame/copper bronze **GO** -british gold **GM** -nero/gunmetal

L3

Miscelatore idroprogressivo con regolatore di portata a parete e bocca di erogazione 130 mm

Wall mounted hydroprogressive mixer with flow regulator and spout 130 mm.
 Wandeinbau hydroprogressiver Mischer mit Durchflussregler mit Auslauf 130 mm.
 Grifo hidroprogresivo mural con regulador de flujo e caño 130 mm.
 Mitigeur hydroprogressif mural avec régulateur de flux e bec 130 mm.

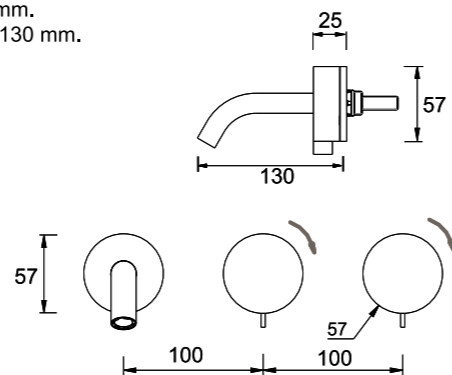

RA -rame/copper bronze **GO** -british gold **GM** -nero/gunmetal

L3

Miscelatore idroprogressivo con regolatore di portata a parete e bocca di erogazione 160 mm

Wall mounted hydroprogressive mixer with flow regulator and spout 160 mm.
 Wandeinbau hydroprogressiver Mischer mit Durchflussregler mit Auslauf 160 mm.
 Grifo hidroprogresivo mural con regulador de flujo e caño 160 mm.
 Mitigeur hydroprogressif mural avec régulateur de flux e bec 160 mm.

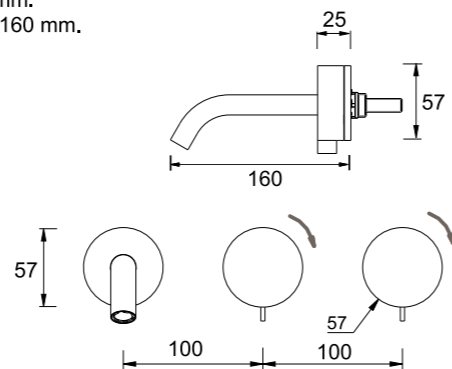

RA -rame/copper bronze **GO** -british gold **GM** -nero/gunmetal

L3

Miscelatore idroprogressivo con regolatore di portata a parete e bocca di erogazione 200 mm

Wall mounted hydroprogressive mixer with flow regulator and spout 200 mm.
 Wandeinbau hydroprogressiver Mischer mit Durchflussregler mit Auslauf 200 mm.
 Grifo hidroprogresivo mural con regulador de flujo e caño 200 mm.
 Mitigeur hydroprogressif mural avec régulateur de flux e bec 200 mm.

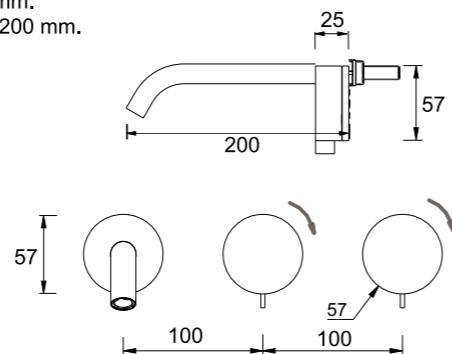

RA -rame/copper bronze **GO** -british gold **GM** -nero/gunmetal

IT	DE	EN	F
SA = Satinato	SA = Satiniert	SA = Satin	SA = Satinée
LU = Lucido	LU = Glanzend	LU = Polished	LU = Poli
PVD = Colori speciali	PVD = Sonderfarben	PVD = Special colour	PVD = Couleurs spéciales

IT	DE	EN	F
SA = Satinato	SA = Satiniert	SA = Satin	SA = Satinée
LU = Lucido	LU = Glanzend	LU = Polished	LU = Poli
PVD = Colori speciali	PVD = Sonderfarben	PVD = Special colour	PVD = Couleurs spéciales

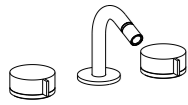

L3

Gruppo rubinetterie bidet appoggio tre fori acqua calda/fredda
 Three-hole bidet mixer complete with spout and command handles for hot and cold water.
 3-Bohrung-Aufsatzbatterie für Becken mit Auslauf und Zweigriffmischer.
 Bateria de superficie 3 taladros para bidé con caño y mando para agua fría y caliente.
 Batterie 3 trous pour bidet avec bec et commandes eau chaude/eau froide.

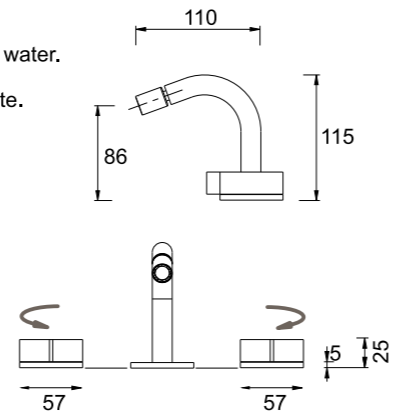

RA -rame/copper bronze GO -british gold GM -nero/gunmetal

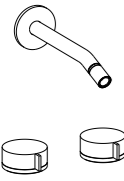

L3

Gruppo rubinetteria bidet acqua calda/fredda appoggio, erogazione a parete
 Two-hole bidet mixer complete with wall mounted spout and command handles hot/cold water.
 2-Bohrung-Aufsatzbatterie für Becken mit Auslauf und Zweigriffmischer.
 Bateria de superficie 2 taladros para bidé con caño y mando para agua fría y caliente.
 Batterie 2 trous pour bidet avec bec et commandes eau chaude/eau froide.

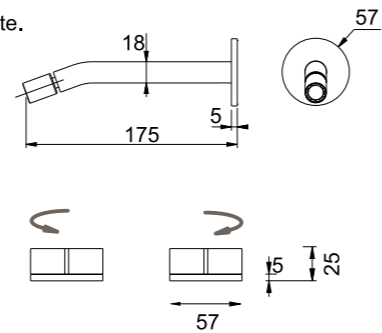

RA -rame/copper bronze GO -british gold GM -nero/gunmetal

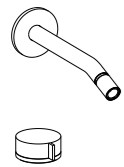

L3

Gruppo bidet con idroprogressivo appoggio ed erogazione a parete
 Kit bidet with hydroprogressive mixer and wall mounted adjustable spout.
 Hydroprogressiver Zweilocharmatur Mischer mit Auslauf.
 Grifo hidroprogresivo con caño mural.
 Mitigeur hydroprogressif avec bec.

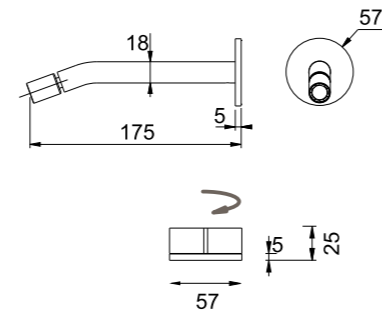

RA -rame/copper bronze GO -british gold GM -nero/gunmetal



L3

Gruppo bidet con idroprogressivo a parete ed erogazione d'appoggio
 Wall mounted hydroprogressive mixer with spout .
 Wandeinbau hydroprogressiver Mischer mit Auslauf.
 Grifo hidroprogresivo mural con caño.
 Mitigeur hydroprogressif mural avec bec.

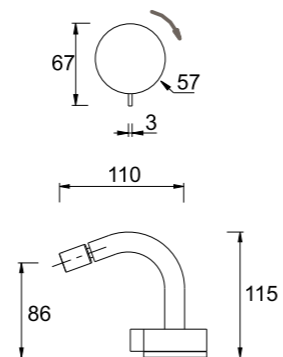

RA -rame/copper bronze GO -british gold GM -nero/gunmetal

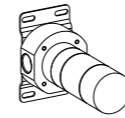

L3

Corpo ad incasso per art. MO11
 Concealed valve for art. MO11.
 Unterputzteil zu art. MO11.
 Mecanismo empotrado para art. MO11.
 Corps d'encastrement pour art. MO11.

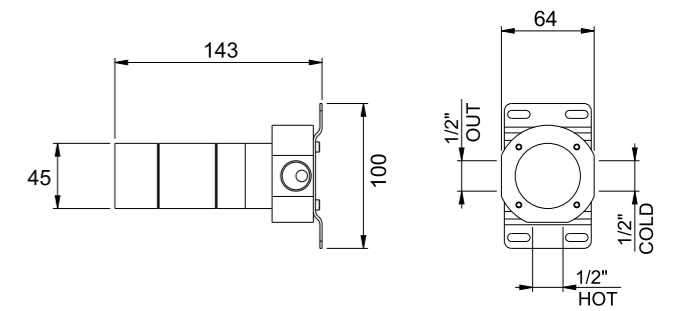

IT	DE	EN	F
SA = Satinato	SA = Satiniert	SA = Satin	SA = Satinée
LU = Lucido	LU = Glänzend	LU = Polished	LU = Poli
PVD = Colori speciali	PVD = Sonderfarben	PVD = Special colour	PVD = Couleurs spéciales

IT	DE	EN	F
SA = Satinato	SA = Satiniert	SA = Satin	SA = Satinée
LU = Lucido	LU = Glänzend	LU = Polished	LU = Poli
PVD = Colori speciali	PVD = Sonderfarben	PVD = Special colour	PVD = Couleurs spéciales

L3

Gruppo doccia/vasca, miscelatore idroprogressivo con deviatore 2 vie

Wall mounted set hydroprogressive mixer with 2 way diverter.
 Wandeinbau hydroprogressiver Mischer mit Umsteller (2 Wege).
 Grifo hidroprogresivo mural con desviador de dos vias.
 Mitigeur hydroprogressif mural avec déviateur à 2 voies.

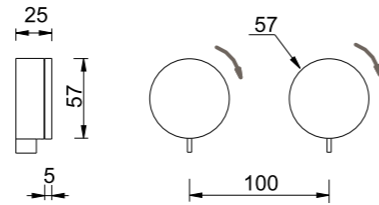
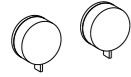

RA -rame/copper bronze GO -british gold GM -nero/gunmetal

L3

Corpo ad incasso per art. MO502

Concealed valve for art. MO502.
 Unterputzteil zu art. MO502.
 Mecanismo empotrado para art. MO502.
 Corps d'encastrement pour art. MO502.

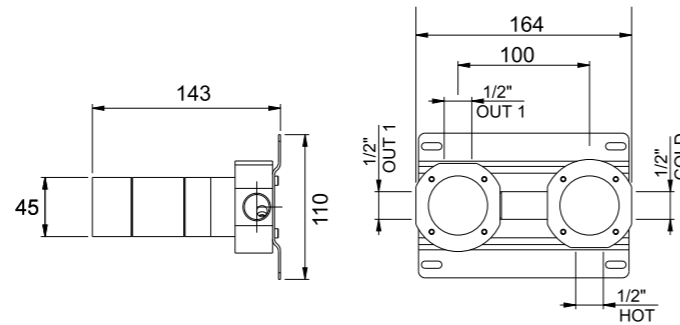
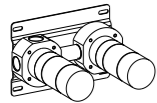

L3

Gruppo doccia/vasca, miscelatore idroprogressivo con deviatore 3 vie

Wall mounted set hydroprogressive mixer with 3 way diverter.
 Wandeinbau hydroprogressiver Mischer mit Umsteller (3 Wege).
 Grifo hidroprogresivo mural con desviador de 3 vias.
 Mitigeur hydroprogressif mural avec déviateur à 3 voies.

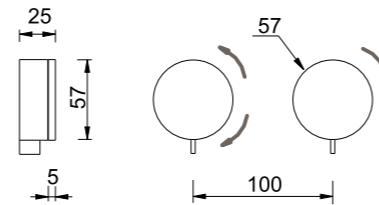
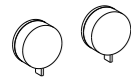

RA -rame/copper bronze GO -british gold GM -nero/gunmetal

L3

Corpo ad incasso per art. MO503

Concealed valve for art. MO503.
 Unterputzteil zu art. MO503.
 Mecanismo empotrado para art. MO503.
 Corps d'encastrement pour art. MO503.

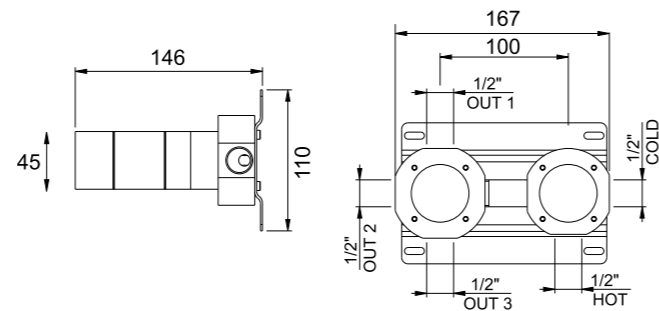
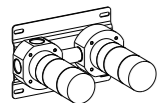

COMPLEMENTI

Canna erogazione bordo vasca forma cigno Ø 27 H 350 mm

Cane dispensing tubside swan shape D. 27 H 350 mm
 Schwanenhalsfoermiger-Auslauf f. Wannenrand H 350 mm Durchm. 27 mm
 Caño de bañera forma de cisne D. 27 H 350 mm
 Canne bord baignoire forme de cygne D. 27 H 350 mm

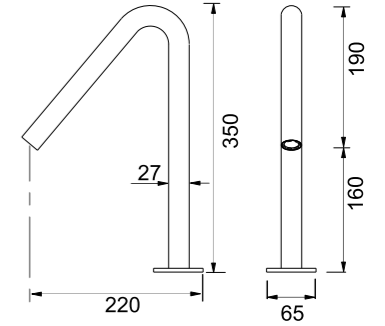
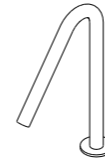

RA -rame/copper bronze GO -british gold GM -nero/gunmetal

COMPLEMENTI

Canna erogazione bordo vasca forma quadra Ø 27 H 280 mm

Cane dispensing tubside square shape D. 27 H 280 mm
 U-foermiger Auslauf f. Wannenrand - Durchm. 27 mm H 280 mm
 Caño de bañera forma cuadrada D. 27 H 280 mm
 Canne bord baignoire forme carrée D. 27 H 280 mm

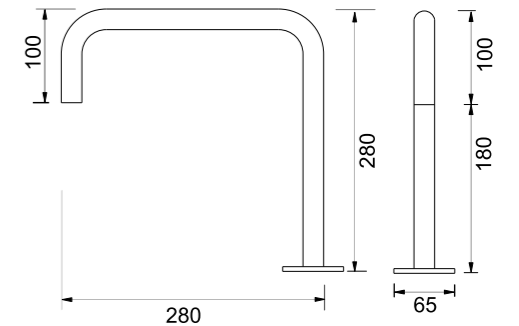

RA -rame/copper bronze GO -british gold GM -nero/gunmetal

IT SA = Satinato LU = Lucido PVD = Colori speciali
 DE SA = Satiniert LU = Glanzend PVD = Sonderfarben
 EN SA = Satin LU = Polished PVD = Special colour
 F SA = Satinée LU = Poli PVD = Couleurs spéciales

IT SA = Satinato LU = Lucido PVD = Colori speciali
 DE SA = Satiniert LU = Glanzend PVD = Sonderfarben
 EN SA = Satin LU = Polished PVD = Special colour
 F SA = Satinée LU = Poli PVD = Couleurs spéciales

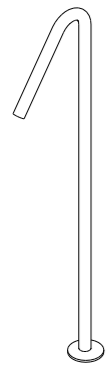

COMPLEMENTS

Canna erogazione vasca da pavimento forma a cigno H 940 mm

Cane bathtub floor swan shape H 940 mm
Schwanenhalsfoermiger freistehender Auslauf H 940 mm Durchm. 27 mm
Caño de bañera suelo forma de cisne H 940 mm
Roseau baignoire sol en forme de cygne H 940 mm

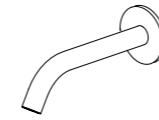
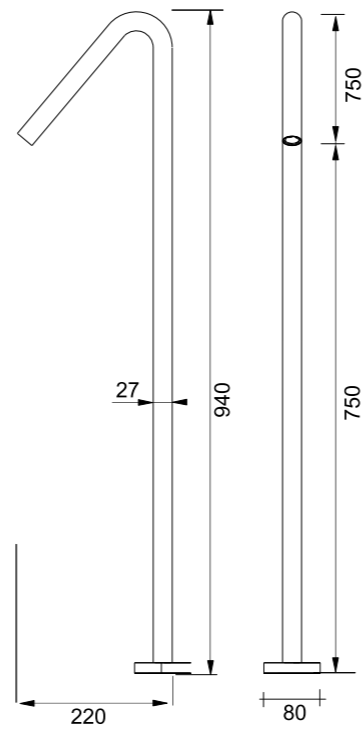

COMPLEMENTS

Bocca erogazione vasca incasso a parete D. 27 P. 200 mm

Wall mount bath spout D. 27 P.200 mm
Wandauslauf - Durchmesser 27 mm - Ausladung 200 mm
Caño de bañera de pared D. 27 P.200 mm
Bec baignoire mur D.27 P.200 mm

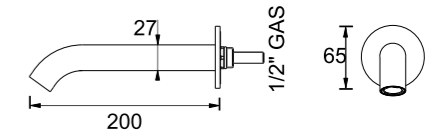

RA -rame/copper bronze GO -british gold GM -nero/gunmetal

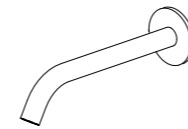

COMPLEMENTS

Bocca erogazione vasca incasso a parete D. 27 P. 250 mm

Wall mount bath spout D. 27 P.250 mm
Wandauslauf - Durchmesser 27 mm - Ausladung 250 mm
Caño de bañera de pared D. 27 P.250 mm
Bec baignoire mur D.27 P.250 mm

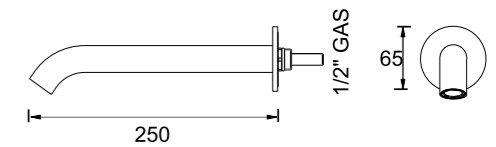

RA -rame/copper bronze GO -british gold GM -nero/gunmetal

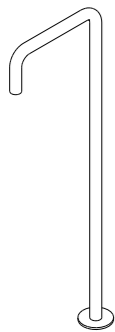

COMPLEMENTS

Canna erogazione vasca da pavimento forma quadra H 865 mm

Cane bathtub floor square shape H 865 mm
U-foermiger freistehender Auslauf H 865 mm Durchm.
Caño de bañera suelo forma cuadrada H 865 mm
Roseau baignoire sol forme carrée H 865 mm

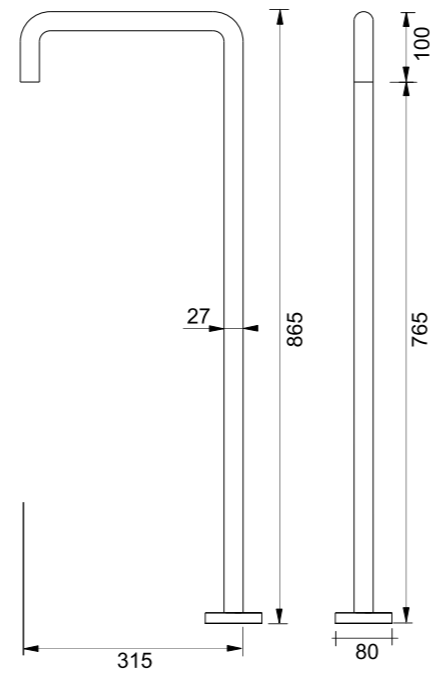

COMPLEMENTS

Corpo incasso bocche lavabo/bidet/vasca a parete

Concealed valve basin - bidet - tub for wall mount spout.
Unterputz-Einbauteil f. Wandauslauf mit Befestigungsplatte
Cuerpo empotrado caño de lavabo - bidé - bañera a pared
Corps encastré bouches lavabo - bidet - baignoire à mur

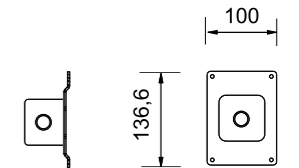

RA -rame/copper bronze GO -british gold GM -nero/gunmetal

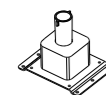

COMPLEMENTS

Corpo incasso bocche lavabo/bidet/vasca a parete

Concealed valve basin - bidet - tub for wall mount spout.
Unterputz-Einbauteil f. Wandauslauf mit Befestigungsplatte
Cuerpo empotrado caño de lavabo - bidé - bañera a pared
Corps encastré bouches lavabo - bidet - baignoire à mur

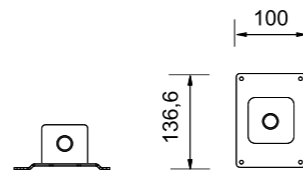

IT
SA = Satinato
LU = Lucido
PVD = Colori speciali

DE
SA = Satiniert
LU = Glaenzend
PVD = Sonderfarben

EN
SA = Satin
LU = Polished
PVD = Special colour

F
SA = Satinée
LU = Poli
PVD = Couleurs spéciales

IT
SA = Satinato
LU = Lucido
PVD = Colori speciali

DE
SA = Satiniert
LU = Glaenzend
PVD = Sonderfarben

EN
SA = Satin
LU = Polished
PVD = Special colour

F
SA = Satinée
LU = Poli
PVD = Couleurs spéciales

COMPLEMENTS

Doccetta a stilo completa attacco a parete con flessibile a molla in inox

Shower hand complete wall connection
Handbrause komplett mit Wandbefestigung
Ducha completa con montaje en pared
Douche complète avec support mural

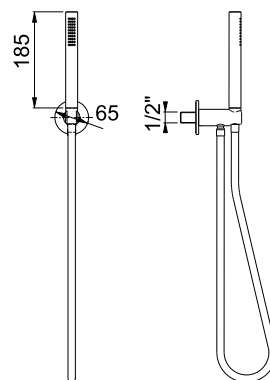
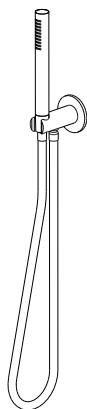

COMPLEMENTS

Doccetta a stilo completa attacco a parete con flessibile in silicone

Shower hand complete wall connection
Handbrause komplett mit Wandbefestigung
Ducha completa con montaje en pared
Douche complète avec support mural

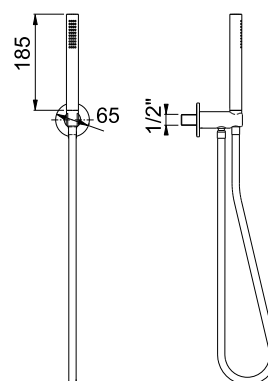
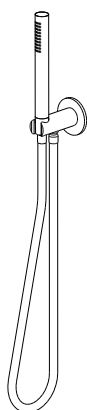

RA -rame/copper bronze GO -british gold GM -nero/gunmetal

COMPLEMENTS

Doccetta a parete DUPLEX completa di flessibile inox

Shower hand complete wall connection
Handbrause komplett mit Wandbefestigung
Ducha completa con montaje en pared
Douche complète avec support mural

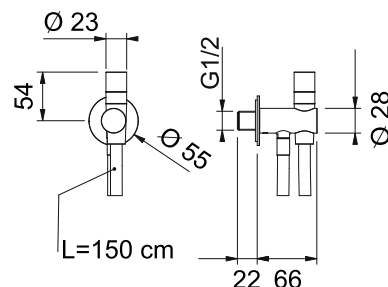
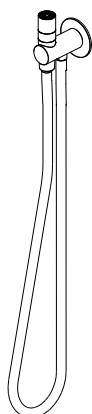

IT
SA = Satinato
LU = Lucido
PVD = Colori speciali

DE
SA = Satiniert
LU = Glänzend
PVD = Sonderfarben

EN
SA = Satin
LU = Polished
PVD = Special colour

F
SA = Satinée
LU = Poli
PVD = Couleurs spéciales